

Spider

Feeding computer

Voercomputer

Fütterungscomputer

Logiciel d'alimentation

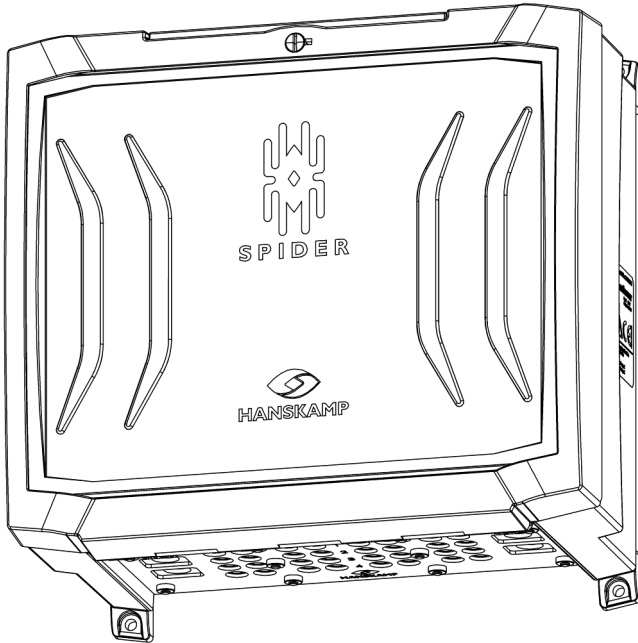

Installation and Operating Instructions

EN

Article number: 010-301-000

Date: December 2025

Version 3.2.2 - Translation of Original Installation and Operating Instructions
According to Annex 1 Chapter 1.7.4 of the Machinery Directive 2006/42/EC



HANSKAMP

Innovation for dairy farming

Wehl,
The Netherlands
www.hanskamp.com

Foreword

Contents of the installation and operating instructions

This manual contains the information necessary for the correct installation and operation of Spider. Study and understand this information thoroughly before configuration of the Spider. Failure to do so could result in damage to equipment.

Please consult your milking equipment dealer if you do not understand the information in this manual, or if you need additional information.

All information in this manual has been compiled with care. Hanskamp shall not be liable for errors or faults in this manual. The recommendations are meant to serve as guidelines. All instructions, pictures and specifications in this manual are based on the latest information that was available at the time of publication. Your Spider may comprise improvements, features or options that are not covered in this manual.

Applicability

The table below shows the type numbers of the Spider for which this manual is applicable.

Model designation

Model	Type number
SpiderServer	005-100-000
SpiderClient	005-115-000

Contact number of milking technology dealer

We recommend that you enter the name, phone number and e-mail of your milking technology dealer in the table below, so that you can always find the right information easily.

Name	
Address	
Telephone number	
E-mail	

1.	Introduction	6
2.	Safety	7
2.1	Introduction	7
2.2	Signal words	7
2.3	Safety instructions	7
2.3.1	General safety	8
2.3.2	Electrical safety	8
2.3.3	Installation safety	8
2.3.4	Operating safety	8
2.3.5	Maintenance safety	9
2.3.6	Safety warnings	9
3.	Installation Hardware	10
3.1	Construction overview Spider	11
3.2	Installation in FeedStation	12
3.2.1	Overview SpiderPCB	14
3.2.2	Assembly examples Spider on FeedStation Walk-In	15
3.2.3	Expanding the SpiderServer with the SpiderClient	16
3.2.3.1	Fitting an SF/UTP cable with network connectors	16
3.2.4	Assembly L'port and/or T'port to Spider	17
3.3	Installation in the milking parlour	19
3.3.1	Connecting the limit switch	19
3.3.2	Examples of installation in the milking parlour	20
4.	Signing in / starting up	21
4.1	Signing in	21
4.1.1	Signing in on a PC or via a home network (optional)	21
4.2	Adding and configuring SpiderPCB	22
4.3	SpiderPCB parameters (transponder configurations)	24
4.3.1	Tag detection	24
4.3.2	Set factory defaults	25
4.3.3	LED test	25
4.3.4	Setting/fine-tuning parameters manually	26
5.	Adjusting the FloorAntenna	27
6.	Using the LED indicators	28
7.	User interface	29
7.1	Updates	29
7.1.1	Internet update	29
7.1.2	USB update	29
7.1.3	Firmware update	29
7.2	Backup	29
7.3	TAURUS-link with management system	30
7.4	Manual motor settings	31
7.5	Calibration	31
7.6	User tips	32
7.7	Reading animal data	33

8.	Explanation of the feeding principle	34
9.	Replacing components	35
9.1	Replacing PCB	35
9.2	Replacing Antenna	35
9.3	Replacing CarrierBoard	35
10.	Extra information	36
11.	Declaration	37
12.	Notifications & FAQ	38
12.1	Notifications	38
12.2	FAQ	39
13.	Appendices	40
13.1	Appendix SpiderServer	40
13.2	Appendix SpiderClient	41
13.3	Appendix Description parts Hanskamp Antenna	42
13.4	Appendix FloorAntenna	43
13.5	Appendix Control motors	44
14.	Accessories	45

1. Introduction

Spider is of interest for dairy farmers who would like to feed automatically, regardless of company size. The Spider consists of a SpiderServer with SpiderAntennas. It can read 16 Antennas, control 16 feed dispensers, and operate 12 air vents within a 10 m range. A motor can be connected to each exit, e.g. a motor that dispenses concentrate.

The electronics in a Spider box are capable of controlling four feeding stations, each with four different types of feed. Using one control box, one type of feed can be dispensed in a 2 x 8 milking parlour. For greater range and/or more outputs, the SpiderServer can be expanded with one or more SpiderClients (same number of outputs as the SpiderServer).

The information in this manual is intended for dairy farmers and technicians.

- Dairy farmers can use the information to test and adjust Spider or to list overviews.
- Technicians can use the information to install and set up the Spider.

2. Safety

2.1 Introduction

The 'Safety Warning' symbol warns about important safety messages on your MultiDos and in the manual. Use caution if you see this symbol; it means there is a risk of personal injury or death. Follow the directions of any safety messages.



Safety Warning Symbol

2.2 Warning Texts

Note the use of the warnings **CAUTION** and **DANGER** in the safety messages. The following guidelines apply to these warnings:



Caution! Indicates a potentially hazardous situation which could result in minor personal injury or damage to equipment or the environment if the warning is ignored.



Danger! Indicates a potentially hazardous situation which could result in death or serious injury if ignored.

2.3 Safety Instructions

You are personally responsible for operating and maintaining your Spider safely. You must make sure that you and anyone else who operates the equipment, performs maintenance on the Spider or works in the vicinity of the Spider, are familiar with all the safety information in this manual.

Safety is in your hands. Proper safety measures protect you and the people around you. Incorporate these measures into your safety programme. Make sure that everyone who uses, carries out maintenance, or works in the vicinity of the Spider is aware of these safety measures. Do not risk injury or death by ignoring the safety precautions.

- Spider owners must train users before the Spider is used. This training must be repeated at least once a year.
- The user must read, understand and follow all the safety and operating instructions in the manual.
- Anybody who has not read and understood all the safety and operating instructions must not operate the Spider.
- Do not make any modifications to the equipment. Unauthorised modifications may affect operation, affect the service life of the equipment, and/or result in personal injury.
- Only use original spare parts, and make sure that they are fitted by authorised technicians.

2.3.1 General Safety

- Make sure you have read and understood the manual and safety instructions before connecting the power supply to operate or adjust Spider or disconnecting it for maintenance.
- Only trained personnel may operate the Spider.
- Install all protective covers and guards before you operate the Spider.
- Wear proper protective clothing and equipment.
- Disconnect and isolate the electrical power supply before you clean or do maintenance on the Spider.
- Make sure that phone numbers of emergency medical care available in your area are at hand.
- If you have any other questions, please contact your milking technology dealer.
- Review all safety-related topics with all users at least once a year.

2.3.2 Electrical Safety

- Only a qualified electrician may install the Spider power supply.
- Check whether the earthing of the electrical system and all parts of the Spider comply with local rules and regulations.
- Replace any damaged electrical lines, conduits, switches and components immediately.
- Isolate the electrical power supply before you open the Spider enclosure to work on the electrical system.

2.3.3 Safety during Installation

- Make sure that you have read and understood the instructions in this manual.
- Make sure the Spider is installed correctly, as described in the manual.

2.3.4 Safe Operation

- Make sure you have read and understood the manual and safety instructions before connecting the power supply to operate or adjust Spider or disconnecting it for maintenance.
- Only trained personnel may operate the Spider.
- Switch off the electrical power supply by pulling the plug out of the power point and secure the plug before you clean or do maintenance on the Spider.
- Install the covers and guards before you operate the Spider.
- Keep hands, feet, hair and clothing away from live parts.
- Keep away unauthorized persons, especially small children, from the Spider at all times.
- Before the electrical supply is attached to the Spider, make sure all parts are installed firmly and that all the parts are in good condition.
- If you have any other questions, please contact your milking technology dealer.

2.3.5 Safety during Maintenance

- Make sure you have read and understood the manual and safety instructions before connecting the power supply to operate or adjust Spider or disconnecting it for maintenance.
- Only trained personnel may service and maintain the Spider.
- Switch off the electrical power supply by pulling the plug out of the power point and secure the plug before you clean or do maintenance on the Spider.
- Wear protective clothing and safety glasses when working on the electrical system.
- Make sure all guards and safety devices are installed when you have finished maintenance work.

2.3.6 Safety Messages

- This chapter lists the general safety messages. Specific safety messages, where potential hazards may arise if the procedures or instructions are not followed, are included in the appropriate sections of this manual.

3. Installation Hardware

General description

The Spider is Hanskamp's feeding computer for automatically dispensing concentrate to individual animals in the milking parlour or feeding station. It is great for any dairy farmer interested in automated and economical feeding, regardless of company size. One of the Spider's perks is that, in most cases, it will work with transponders you already have.

The Spider's user interface has been designed in a logical way, making it easy to control Spider from your PC, smartphone, or tablet. The SpiderServer establishes its own wi-fi network, providing access to the built-in web server and allowing you to quickly and easily adjust concentrate portions for individual animals or groups, and monitor problem animals.

This instruction will help you to install the Spider. Read this instruction carefully and follow the safety instructions. Examples of installation can be found at www.hanskamp.com. The order numbers and names of accessories can be found in attachments 13.1 (SpiderServer) and 13.2 (SpiderClient).

Transport and storage

Spider will be shipped in a sealed box. The box is completely sealed with tape and lined with protective foil on the inside to prevent damage. The Spider shall also be stored in this way.



Caution! Always move the box carefully!



Caution! When opening the packaging, parts may fall out. Make sure the packaging is always facing up upon opening!



Caution! When opening the packaging beware of damage and loose and protruding parts that could cause injury!

Safety stickers

The user and installer are responsible for operating and maintaining the Spider safely. Safety stickers are used to ensure safety in and around the Spider. These stickers must be placed correctly. There is one safety sticker applicable to Spider (see below). This sticker must be placed on the right or left side of the unit.

Applying the stickers

- Make sure the surface is dry and clean.
- Make sure the surface temperature is at least 5°C.
- Find the right position for the sticker.
- Remove a small part of the foil on the back.
- Place the sticker on the surface and press a small part of the self-adhesive layer onto the surface.
- Carefully remove the foil and press down the rest of the sticker.
- Remove any air bubbles with a needle and use the foil to smoothen the sticker.

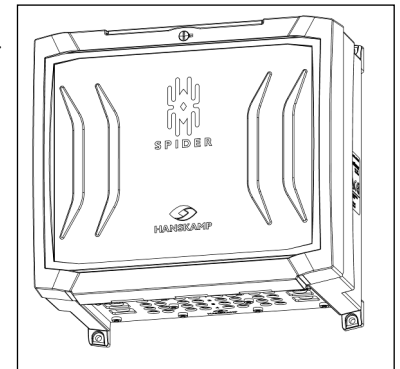

Supply specifications

The box contains:

1. SpiderServer 005-100-000
 2. PowerUnit 002-812-000
 3. X number of Antennas 005-150-000
- Optional:
4. SpiderClient 005-115-000

Type description; can be found on the side of the enclosure

Product name

Product specifications



Contact

UKCA/CE marking

3.1 Construction overview Spider

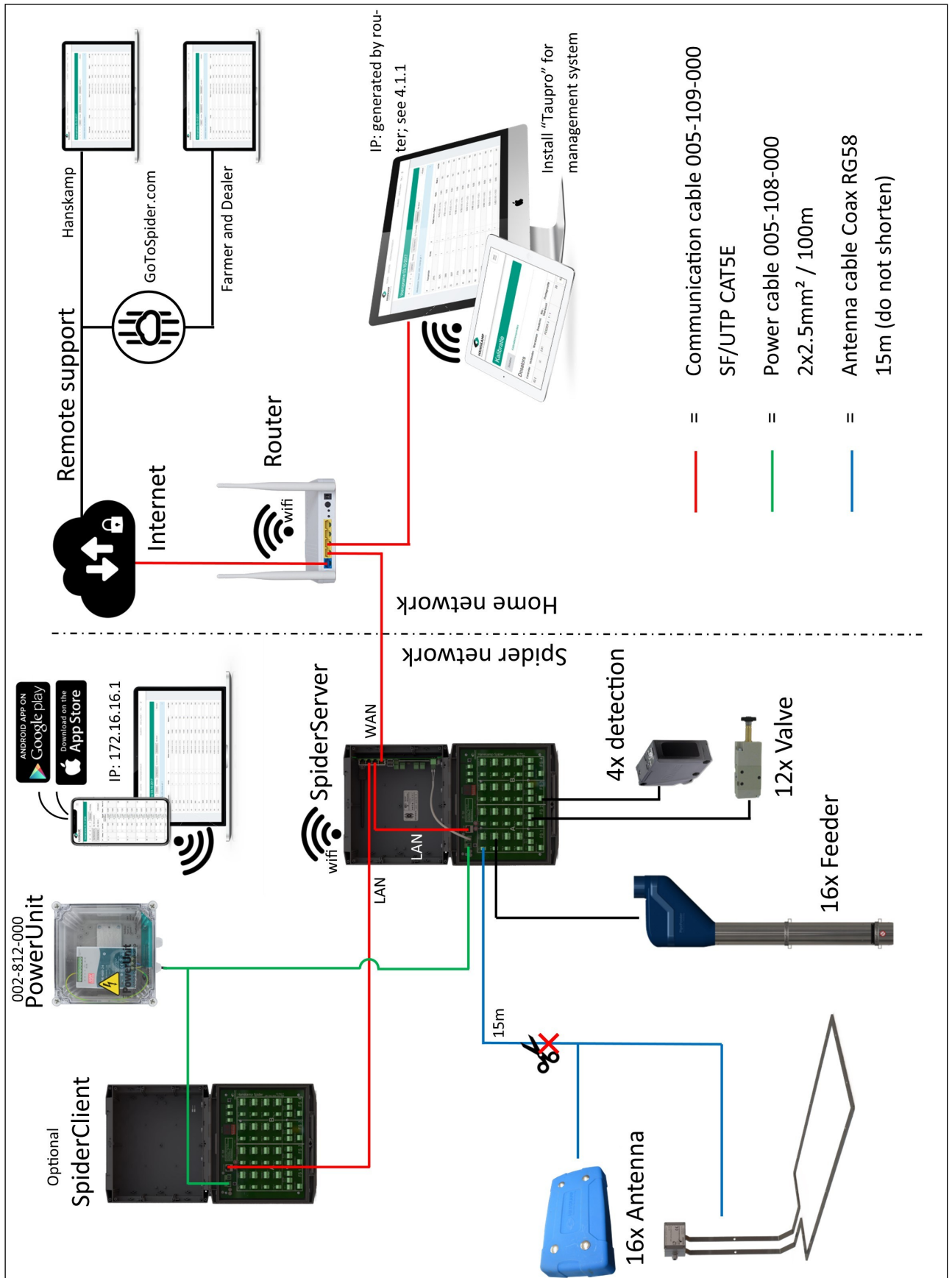

3.2 Installation in FeedStation

1. Check if all components are present according to the parts list at the back of the manual.
2. Find a location for the Spider near the feeding station (max. 10 meters distance). The location must be dry, easily accessible and have a power supply (24VDC PowerUnit). Once a suitable location has been found, the Spider can be installed. Use the included mounting hardware to attach the unit's mounting feet to the outside of the case. To attach the Spider to the feeding station, use the case mounting plate (art. no. 004-247-000). Install the SpiderServer on one side and the PowerUnit (art. no. 002-812-000) on the other.
3. Install the SpiderAntenna on the feed trough and run the cable to the Spider unit. Make sure that it is out of reach of the animals (fig. 1). See chapter 3.2.2 for ear and leg recognition.

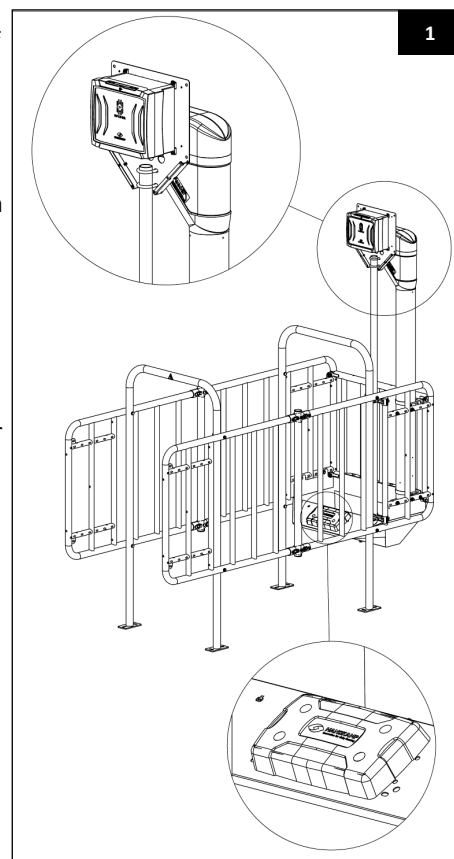

Caution: The Antenna cable must not be shortened. Shortening the cable will negatively affect Antenna performance.

4. Connect the SpiderAntenna to the SpiderPCB as illustrated in figure 2. The core is + and the sheath is -.

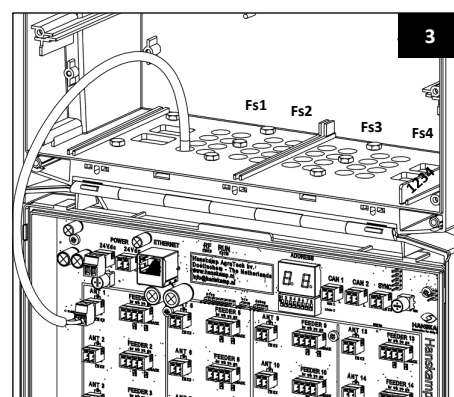
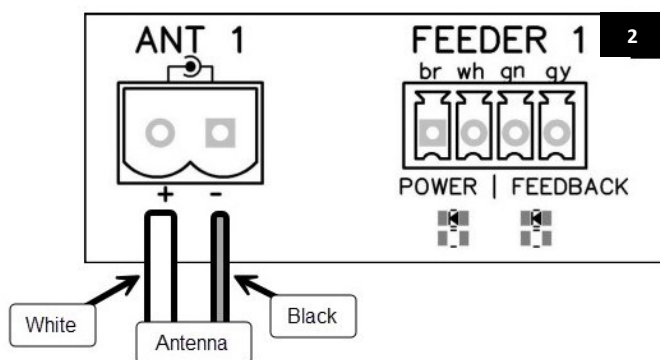

All inputs and outputs are numbered, as is the cable entry plate (art. no. 005-161-001) (fig. 3). Ensure that the holes line up with the inputs and outputs to keep the cables uncluttered.

Example: 4 feeding stations with 4 feed types and a closing gate (fig. 4).

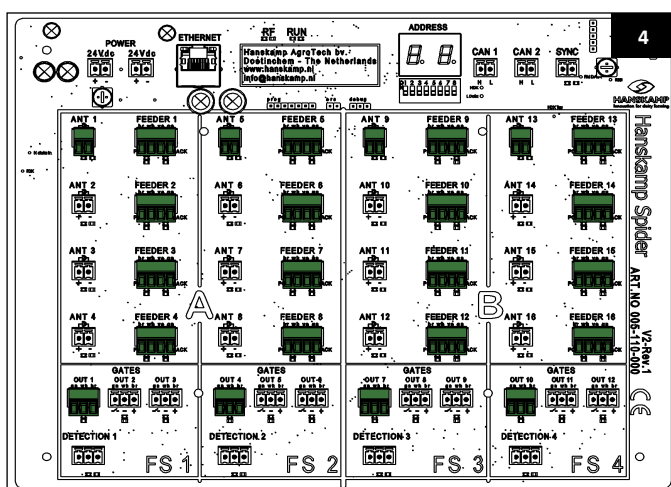

Caution! A black Antenna is 120 kHz!

Feeding computer - Voercomputer - Fütterungscomputer - Logiciel d'alimentation

The SpiderPCB can be freely configured, allowing control of up to 16 feeding stations with 1 feed type. If this is not enough, the SpiderServer can be expanded with a SpiderClient, doubling the number of inputs and outputs. Connect the units with a shielded data cable (art. no. 005-109-000 SF/UTP CAT5E).



Caution! The feeding stations must not be more than 10 meters apart, as the Antenna cable is 15 meters long. If they are further apart, you will need to use an extra SpiderClient.

- Use the data cable (art. no. 005-107-000) to connect the SpiderPCB to the CarrierBoard. The SpiderClient can be connected in the same way. Use the ethernet (LAN) ports on the CarrierBoard and SpiderPCB. The ethernet (LAN) ports on the CarrierBoard serve as a switch. Do NOT connect the SpiderPCB or SpiderClient to the WAN port on the left (fig. 7).

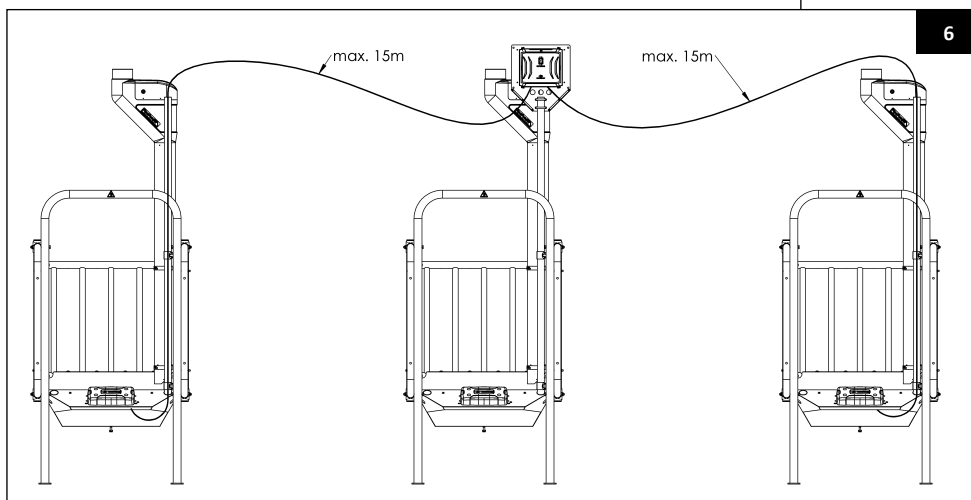
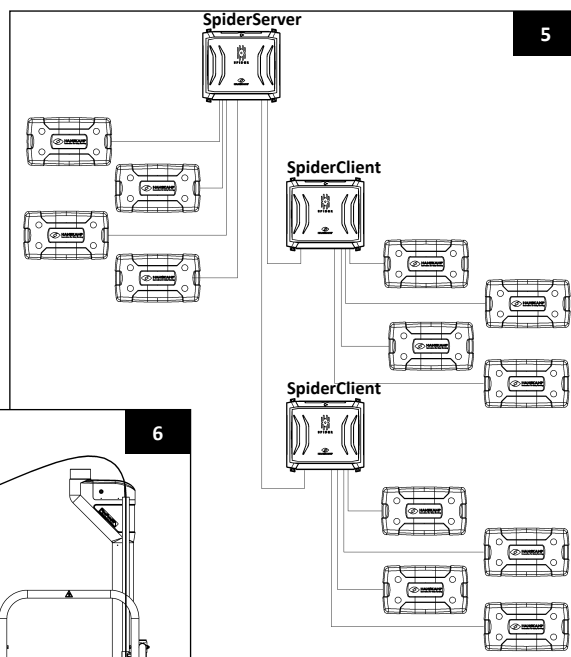

- Connect the CarrierBoard and the SpiderPCB to the 24VDC power supply. The SpiderPCB comes with two power ports which are linked internally. The second port can be used to power the CarrierBoard (fig. 8).
- An extra data cable (art. no. 005-109-000) is required to connect the Spider to a PC in your home network. Connect the extra data cable to the WAN port on the CarrierBoard and the router in your home network. The Spider can then be accessed through the web browser on any PC in the network. See chapter 3.2.3.1 for information on fitting data cables.



Please note! If the SpiderServer and router are more than 100 meters apart, a switch must be used in between.

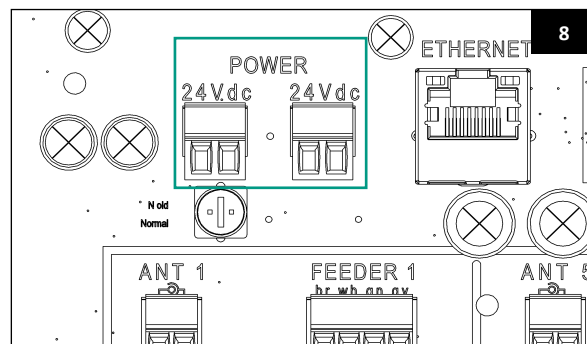
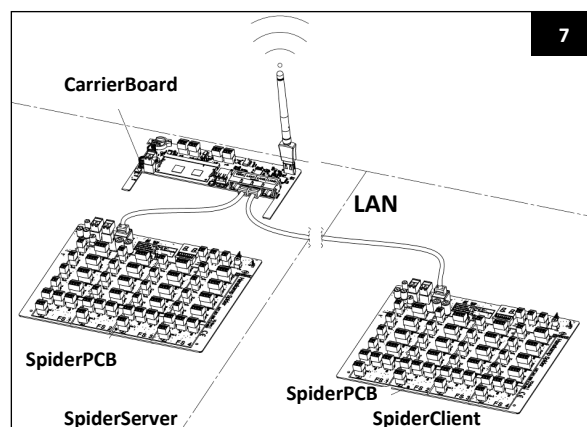

3.2.1 Overview SpiderPCB

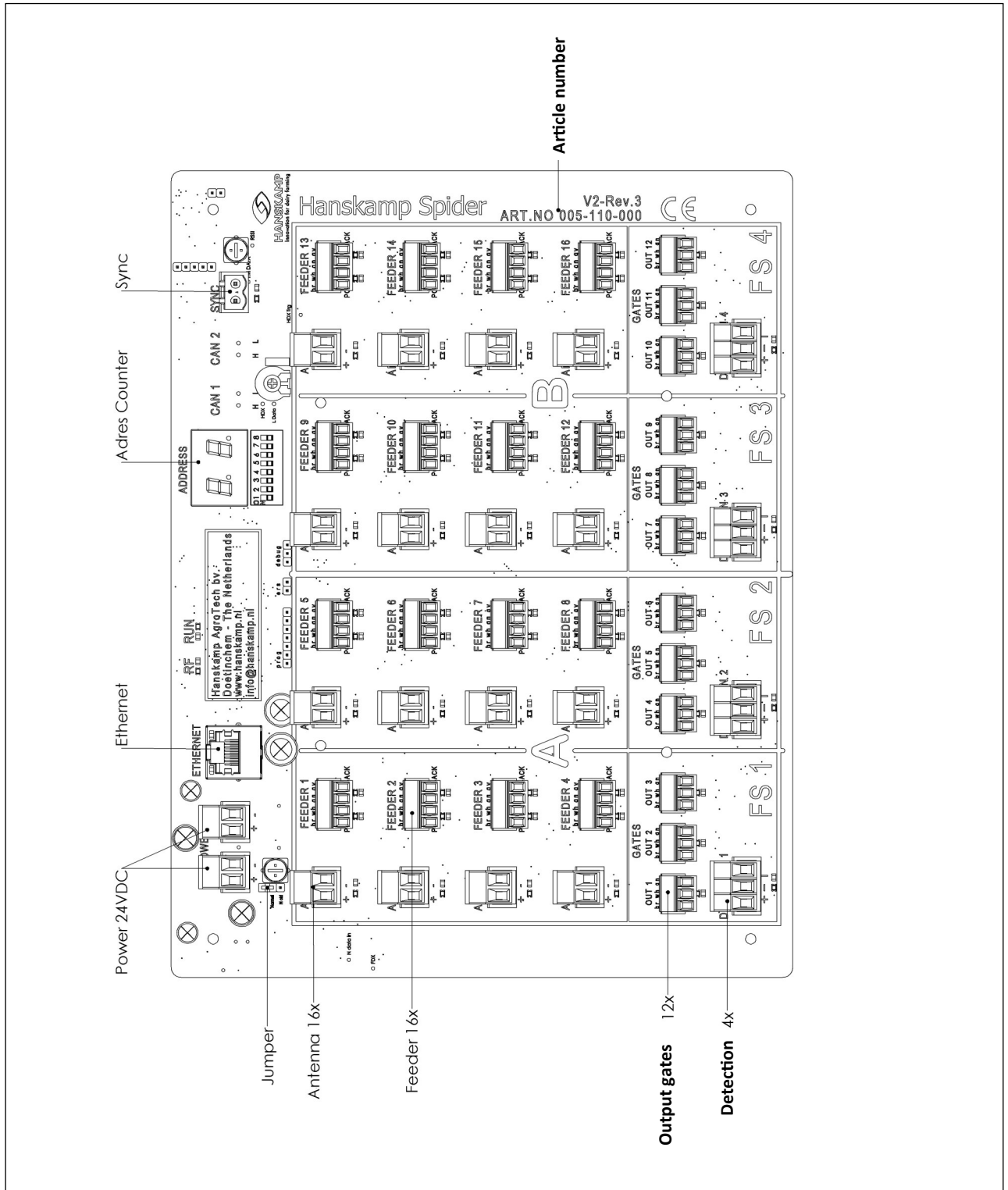

3.2.2 Assembly examples Spider on FeedStation Walk-In

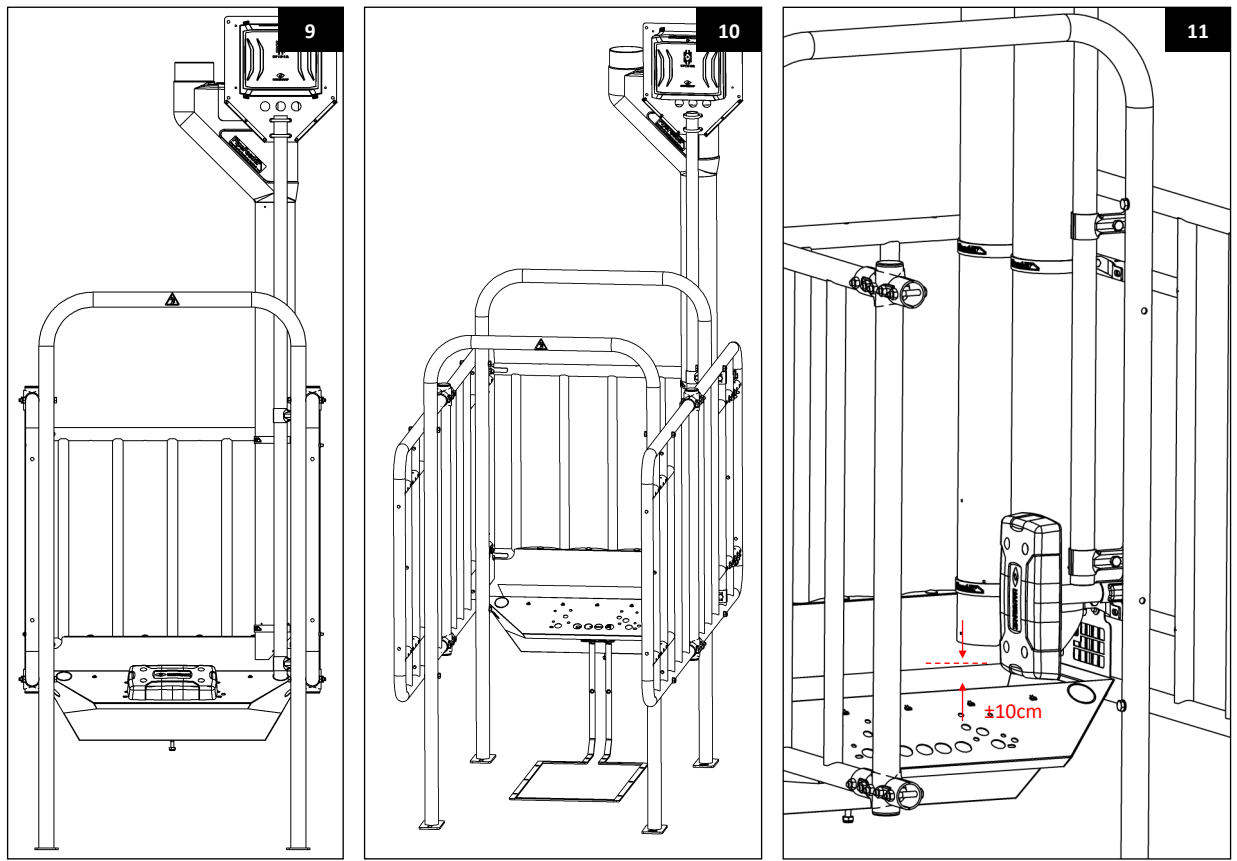
**Neck recognition**

Neck recognition can be mounted directly to the feed trough (figure 9).

Leg recognition

Ensure that the EWA Antenna Transformer unit (art. no. 005-175-000) is located under the feed trough mounting plate and that the Antenna cannot come into contact with the feed trough (figure 10).

Ear recognition

Use the mounting plate (art. no. 004-246-000) to install the Antenna for ear recognition. Place the Antenna on the same side as the PipeFeeder (figure 11).



Caution! Run the Antenna cable through the tubes carefully to prevent damage to the cable.

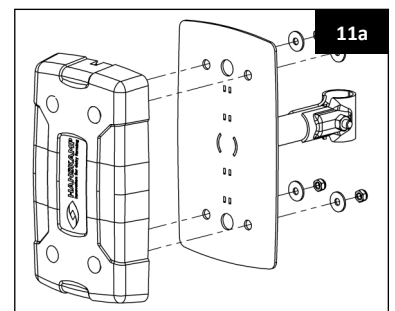
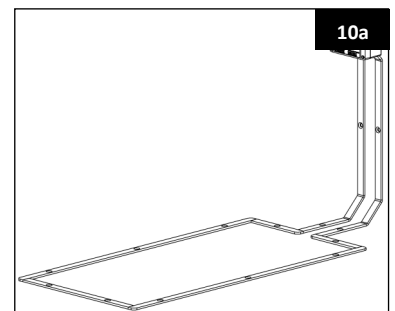
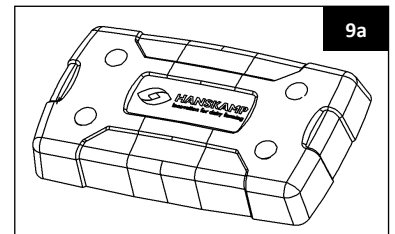

3.2.3 Expanding the SpiderServer with the SpiderClient

Install the SpiderClient in the same manner as the SpiderServer, near or on a feeding station. The SpiderServer and SpiderClient must not be more than 100 meters apart.

Use a data cable (art. no. 005-109-000) to connect the SpiderClient to the SpiderServer. Cut the SF/UTP cable to size before installation (see fig. 7 on page 13).

3.2.3.1 Fitting an SF/UTP cable with network connectors

Hanskamp offers a set with a crimping tool and tester for fitting and testing cables (art. no. 005-166-000).

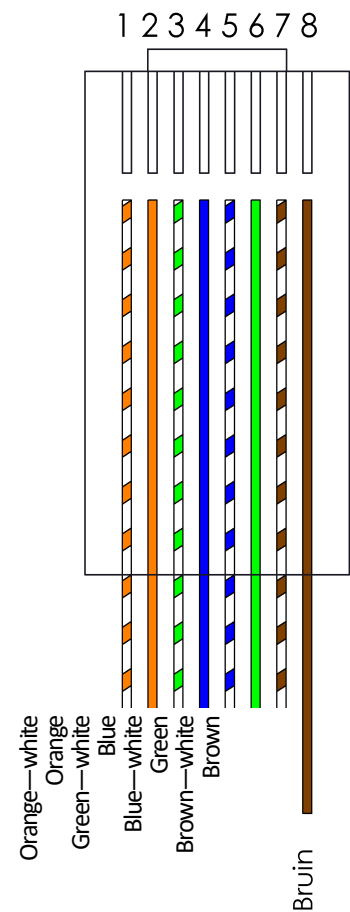
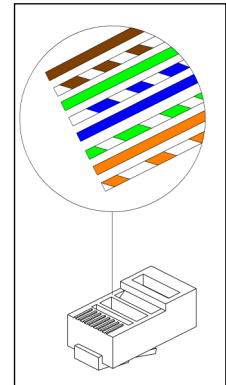
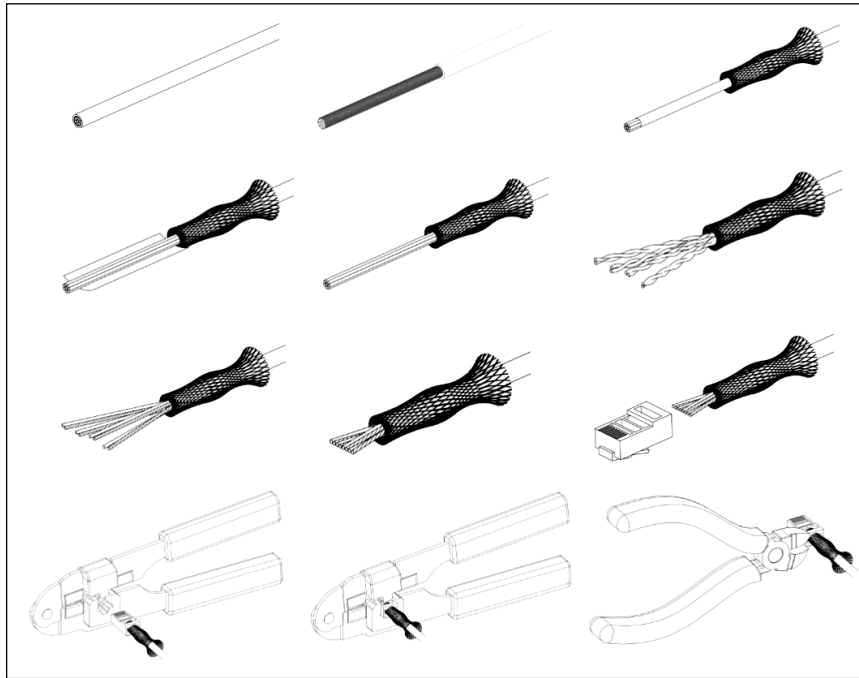

3.2.4 Assembly L'port and/or T'port on Spider

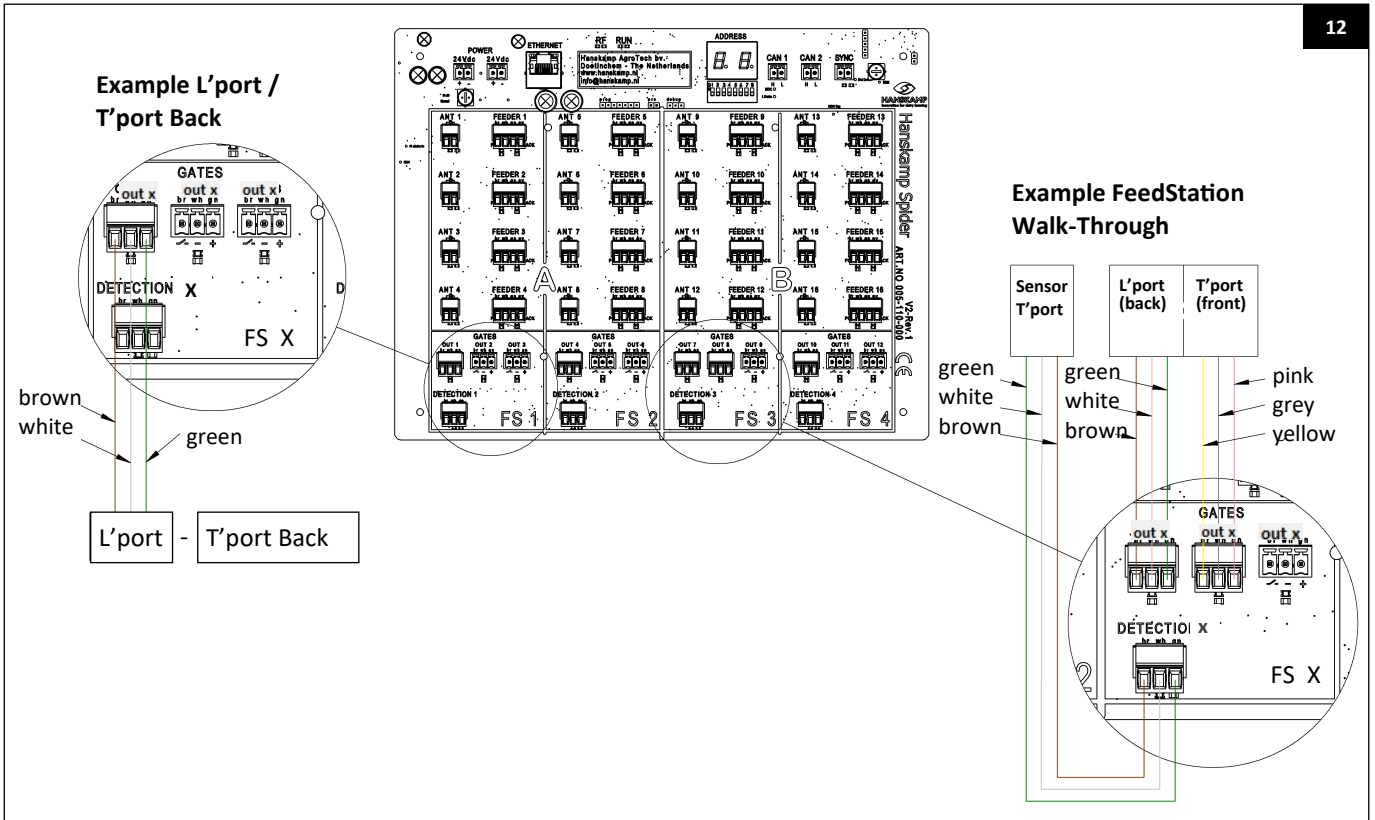

L'port connection diagram (control unit art. no. 002-480-001). If the switch works the other way around, rotate it by 180 degrees.

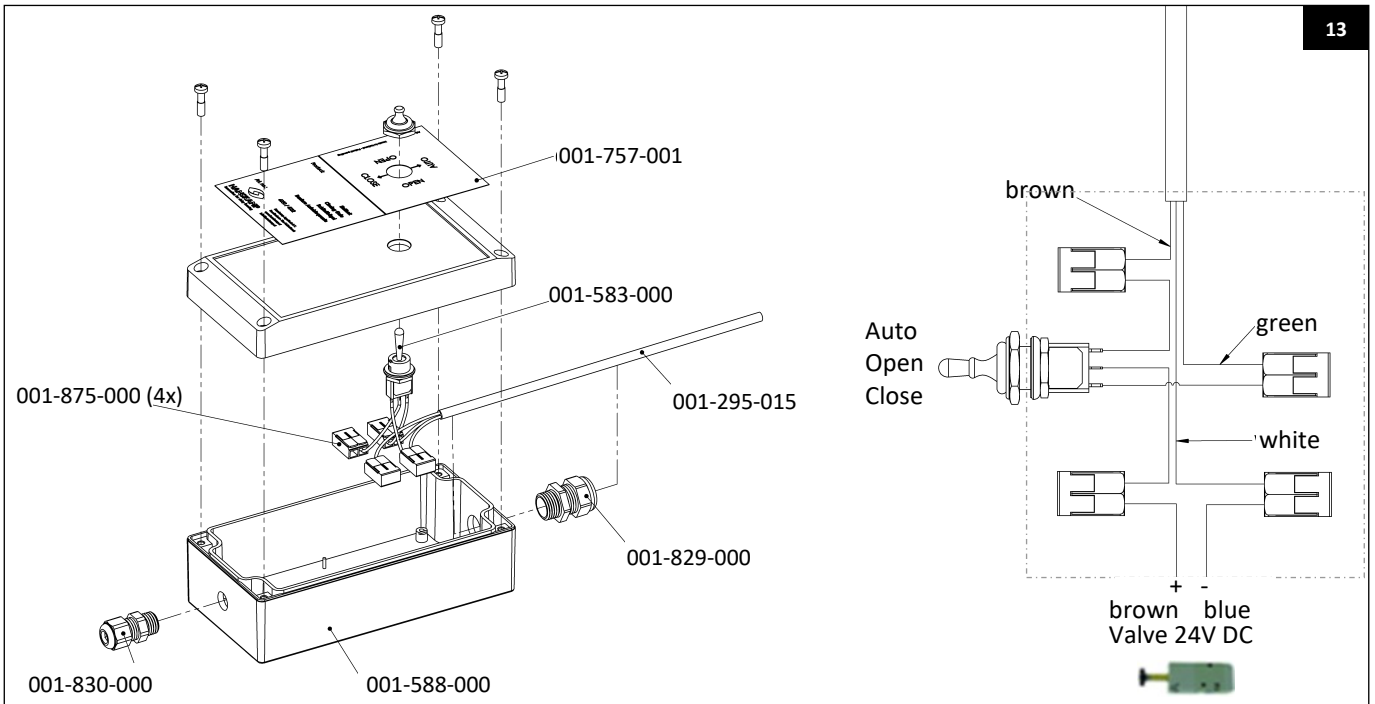

Wiring plan L'port & T'port FeedStation Walk-Through (control box art. no. 002-481-001). If the switch works the other way around, rotate it by 180 degrees.

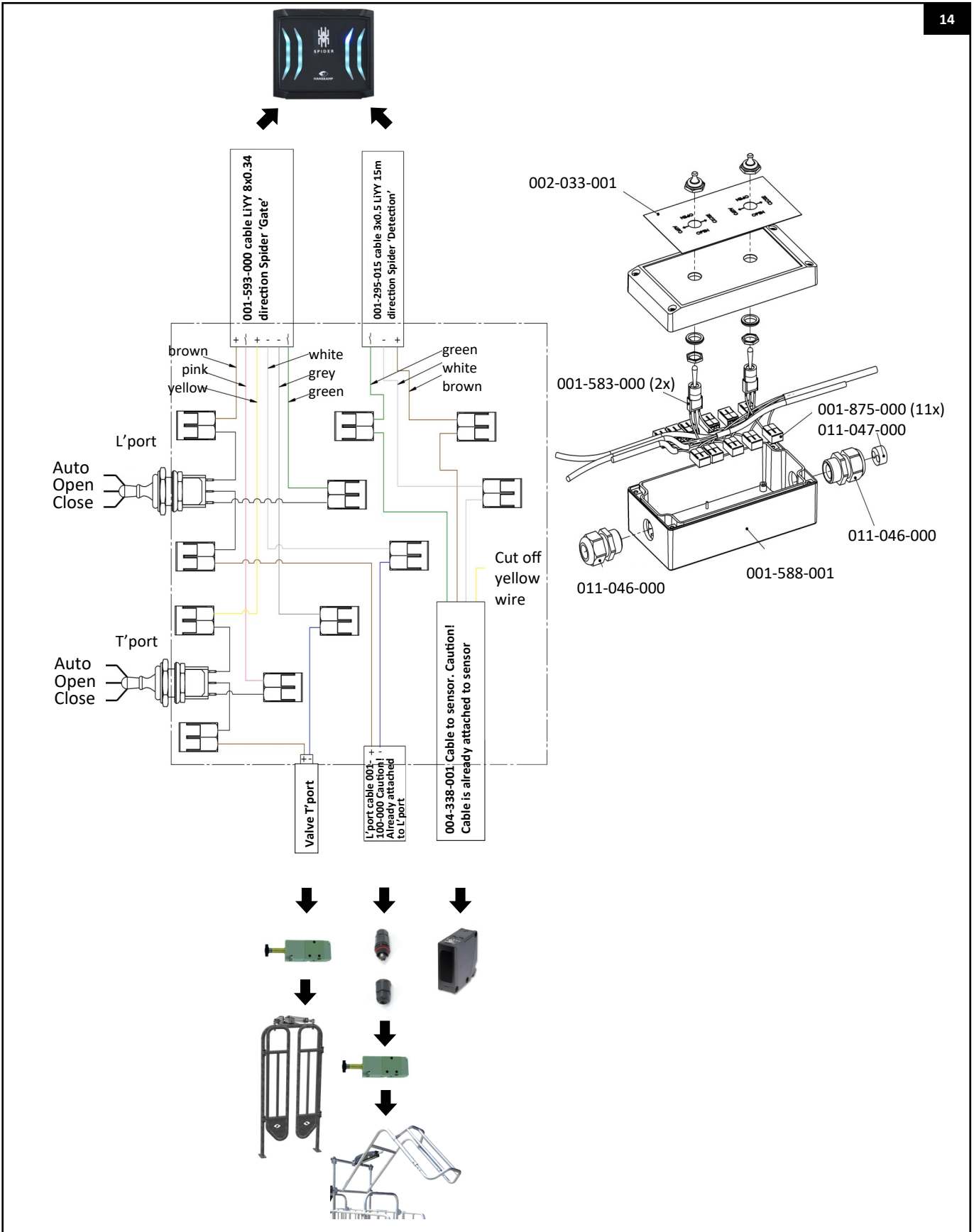

3.3 Installation in the milking parlour

As Spider has 16 Antenna inputs and 16 feed outputs, it can also be used for individual feeding in the milking parlour. Every position can be seen as a feeding station. Please refer to chapter 3.2.1 for instructions on how to connect.

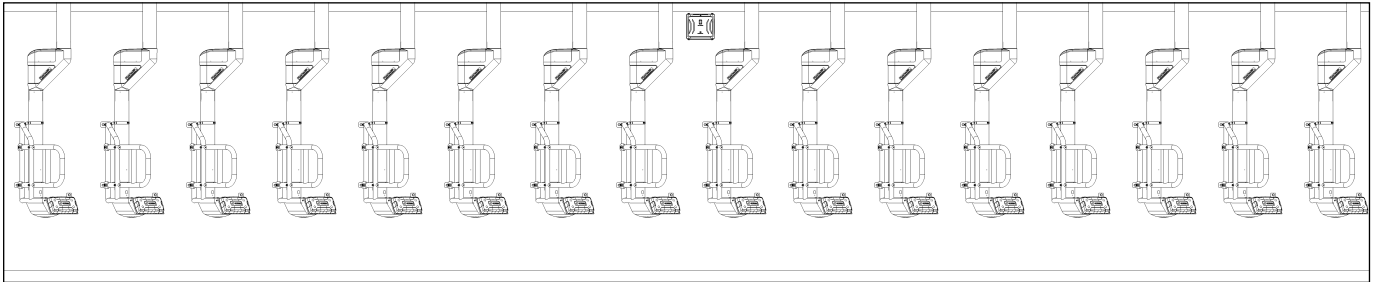

3.3.1 Connecting the limit switch

A limit switch can be installed to prevent animals from being recognised and stopping before the last stall. The limit switch deactivates the Antennas during the switch. This prevents feeding until all the cows are in the correct position. The below example shows the correct set up for a 2x8 milking parlour.

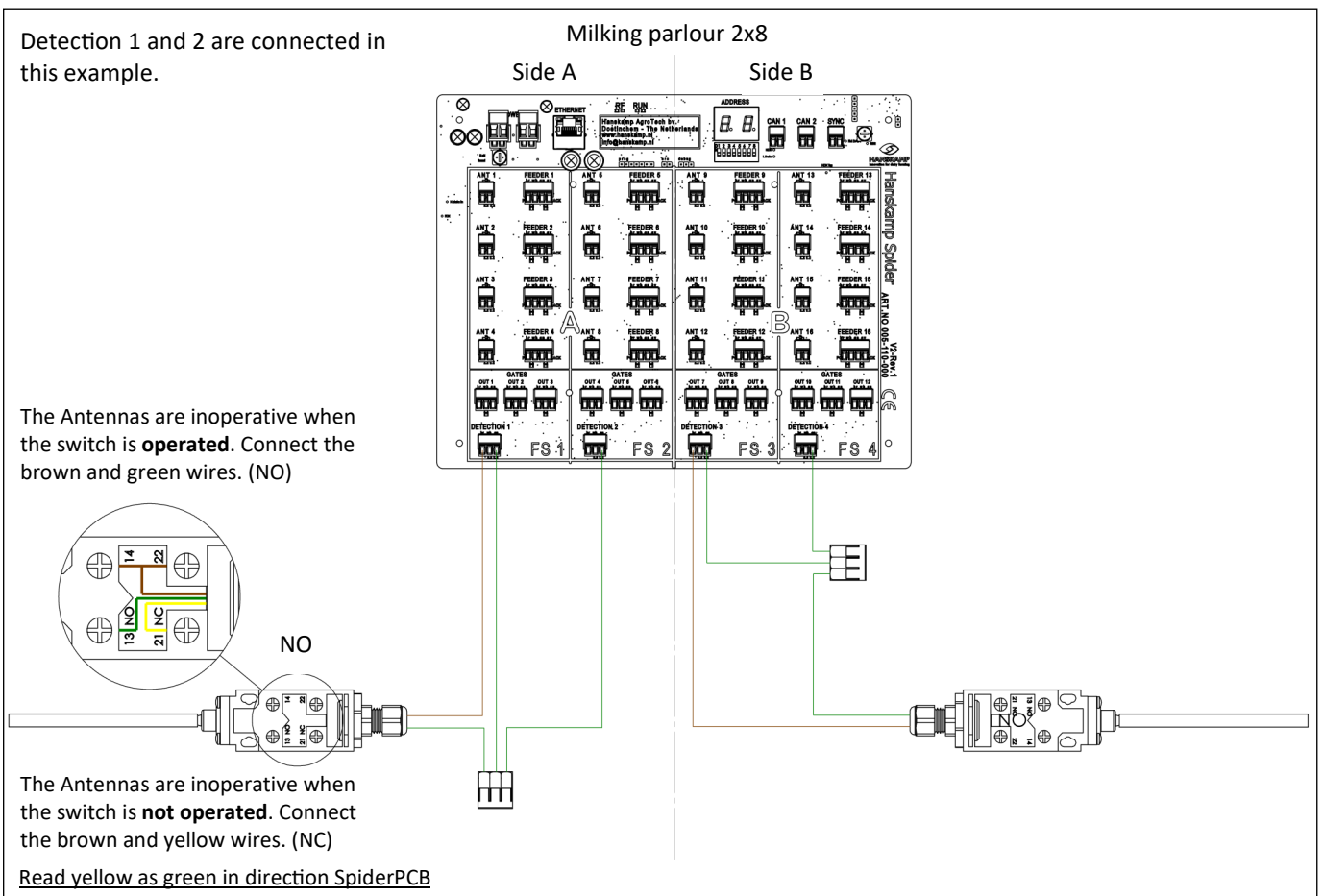

Detection port	1	works for feeder	1-4
	2	works for feeder	5-8
	3	works for feeder	9-12
	4	works for feeder	13-16

This can be continued as in the example. In this instance, one switch is used for feeders 1-8 and one for feeders 9-16.

3.3.2 Examples of installation in the milking parlour

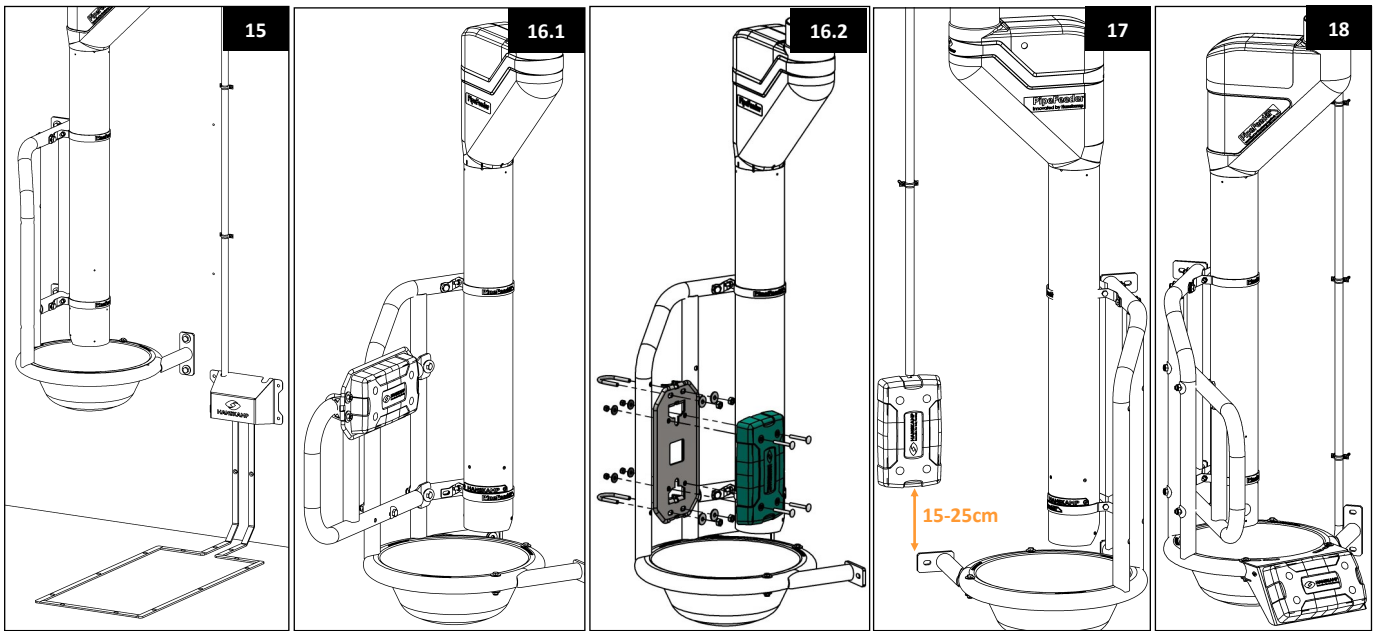
**Leg recognition - figure 15**

To determine the position of the Antenna, consider the position of the animal and where the transponder will be situated. Ensure that the animal's transponder is within the boundaries of the Antenna.

Ear recognition - figure 16 - 17

Use the mounting kit (art. no. 007-535-000) for installation on the MultiFrame (40° - 50° & 60° - 70°). Because the animals all have their ear transponders on the same side, the Antenna must be installed on the opposite wall of the milking parlour. The cable can be run through the side by breaking off the tab on the Antenna (fig. 19).

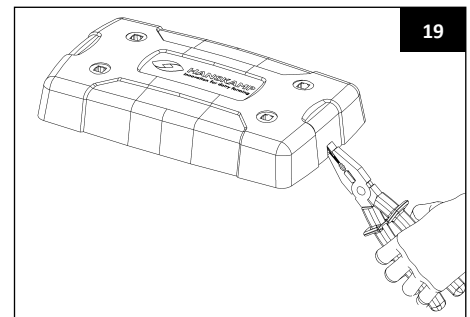
**Neck recognition - figure 18**

A mounting bracket (art. no. 007-525-000) is available for installing neck recognition.

005-124-000 Cluster antenna for leg transponder - figure 20

This antenna can be used in milking parlours for goats and sheep. One of the hind legs is fitted with a band with an HDX or FDX (ear) transponder. The antenna is mounted on the teat cup using the supplied O-ring. In the movement of hanging the teat cup underneath, the teat cup with antenna passes along the leg transponder and the animal is identified.

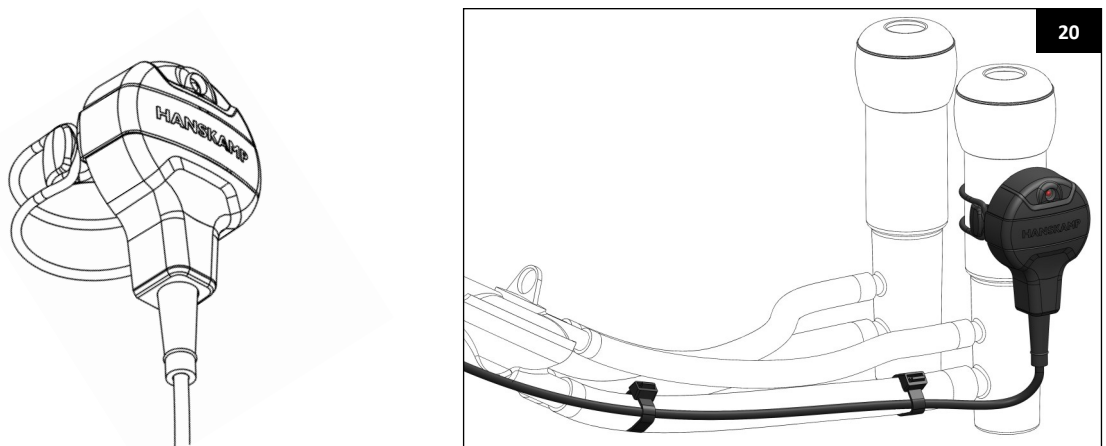

4. Signing in / starting up

4.1. Signing in

Once all the hardware has been installed, the system can be connected to the power supply (24VDC). Remove the paper between the battery and the tab of the battery compartment to allow contact. The SpiderServer will establish a wi-fi network (± 30 meters around the SpiderServer). Use this wi-fi to connect a laptop, phone, or tablet to the Spider network.

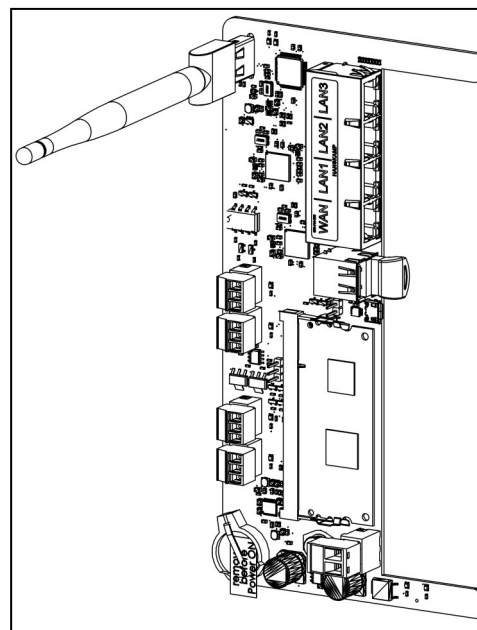

Depending on the device you use, go to the Play Store or App Store, search for 'Hanskamp Spider' and install the app.

- Open your device's wi-fi settings.
- Select the '**SPIDER**' network and enter the password '**hkfsspider**' to connect.
- The user interface can be accessed by the Hanskamp Spider app.

You are now on the main page of the user interface. If you experience problems with logging in, refer to chapter 12.2 FAQ -> 'Log in'.



4.1.1 Signing in on a PC or via a home network (optional)

It is also possible to connect a PC or laptop with a cable. Connect the cable between the **PC** and **LAN**. Spider can then be accessed via the SpiderConnect app.

If you would like to access the user interface from a PC at home or another mobile device, the Spider must be connected to the home network's router and in the Spider to the **WAN** connection. This also allows you to create a wi-fi signal in the barn which is connected to the internet.

SpiderConnect app for PC

Spider can be accessed via the SpiderConnect app. The app can be downloaded at hanskamp.com/brochures-downloads. Search for '**Spider**', then choose '**SpiderConnect for PC**'. Install the downloaded SpiderConnect app via SpiderConnect setup. A warning may appear that your PC is protected. Click on 'More information' and 'Run anyway' and then '**Next**' and '**Yes**'.

If you experience problems with signing in, refer to chapter 12.2 FAQ -> 'Log in'.

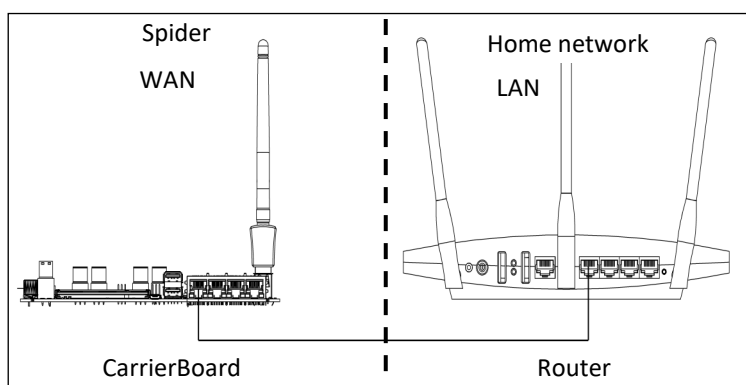

4.2 Adding and configuring SpiderPCB

Go to 'Maintenance' and log in with the administrator password.

Then go to 'Settings' -> 'Configuration SpiderPCB'. The below screen will open (figure 1).

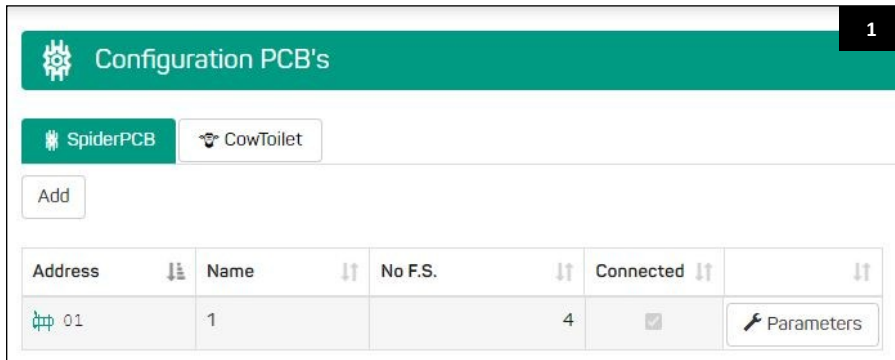

Select the SpiderPCB (fig. 1) to be configured. The screen will open as shown in figure 3. Select 'Add' if no SpiderPCB is displayed or if an additional one needs to be added. Then the next screen will open (figure 2). Select the number of feeding stations you want to add, as well as the number of feed types per feeding station. Select the motor type. Note: these are preconfigured settings and can be changed in the next screen. Once the selection has been made, click 'Apply'.

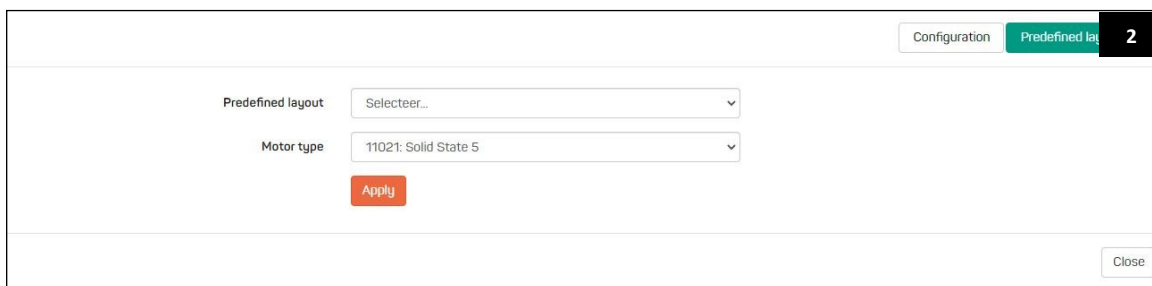

The screen will open as shown in figure 3. Configure your feeding station here. Click on 'Predefined layout' to choose from the most common formats. Change the address, description and settings if necessary.

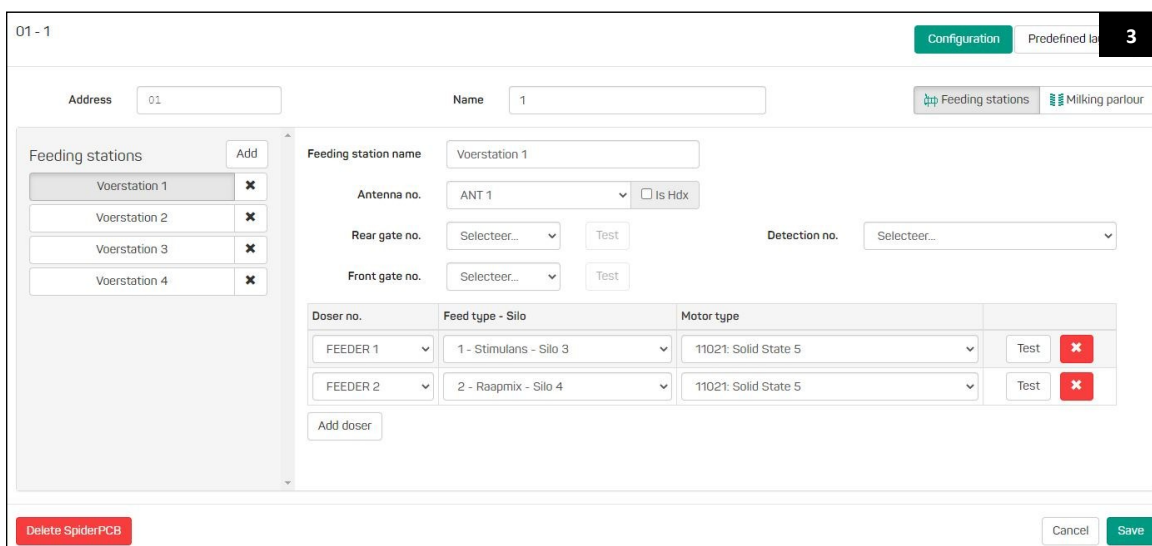

Feeding computer - Voercomputer - Fütterungscomputer - Logiciel d'alimentation

Address: The default address is '01'. If there is more than one PCB, make sure to assign each PCB its own address.

SpiderPCB: Give the SpiderPCB a name, e.g. 'SpiderServer'.

Select a feeding station: Select the feeding station you want to configure.

Description: Feeding station name, e.g. 'Feedstation 1'.

Antenna no.: The exit number on the SpiderPCB which the Antenna is connected to. The checkmark indicates whether the HDX reader is activated.

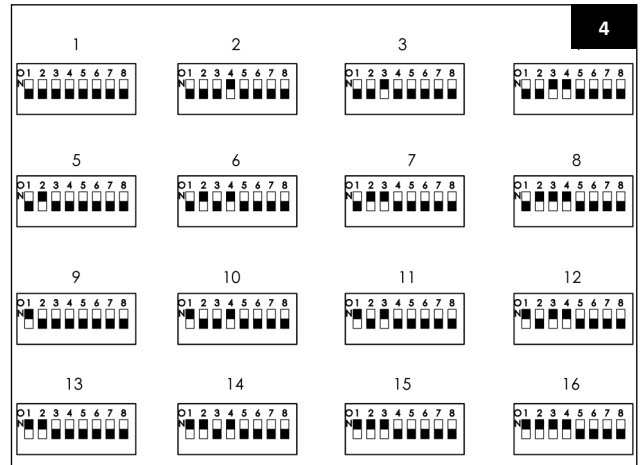

Closing gate no.: The exit number which the closing gate is connected to; these outputs can be found in blocks of 3 at the bottom of the SpiderPCB.

Test: Test proper functioning of the closing gate.
Auto: If present, the closing gate will be automatically actuated.
On: The closing gate will be actuated and will close.
Off: The closing gate will remain open.
Disabled: The closing gate is disabled.
No closing gate: Click 'Select'.

Front gate no.: The exit number which the T'port is connected to. Note: this only applies to the FeedStation Walk-Through.

Test: Test the proper functioning of the front gate.
Auto: If present, the front gate will be automatically actuated.
On: The front gate will be actuated and will close.
Off: The front gate will remain open.
Disabled: The front gate is disabled.
No front gate: Click 'Select'.

Detection no.: The number on the SpiderPCB which the sensor is connected to; these are the bottom ports on the SpiderPCB. Note: Only in combination with T'port.

No detection: Click 'Select'.

Dispenser number: Specify which exit on the SpiderPCB the motor is connected to.

Feed type - Silo: Specify which feed type and silo correspond to this dispenser.

Motor type: Specify which motor the dispenser has. For manual settings, see chapter 7.4.



Note! Dispenser no. 'FEEDER1' is connected to exit 'FEEDER1' on the SpiderPCB. Ensure that a feeder is connected to the number entered. Press 'TEST' to check this.

Complete these steps for all SpiderPCB's and click 'Save'.

4.3 SpiderPCB parameters (transponder configurations)

To change the settings of the SpiderPCB (e.g. settings of transponders and Antennas), go to 'Parameters'.

- Go to 'Maintenance' and sign in as administrator.
- Go to 'Settings' -> 'Configuration SpiderPCB' and select tab 'Parameters'.



The below screen will open:



The submenus and installation process are explained below.

4.3.1 Tag detection

Tag detection (tag tuning) is used for automatic programming of the SpiderPCB's RFID settings; every SpiderPCB must be configured separately. With tag detection, all transponder settings are set correctly, and all connected Antennas are properly adjusted. (See chapter 5 for FloorAntenna.)

Configuring the transponder:

- If the old (120 kHz) responder by Nedap is used, move the jumper on the SpiderPCB to N old (see image on the right).
- Place any transponder used by this customer on the first connected Antenna.
- Click on 'Tag Detection' and then on 'Start' (see page 25).
- Wait until the tag detection process is completed.

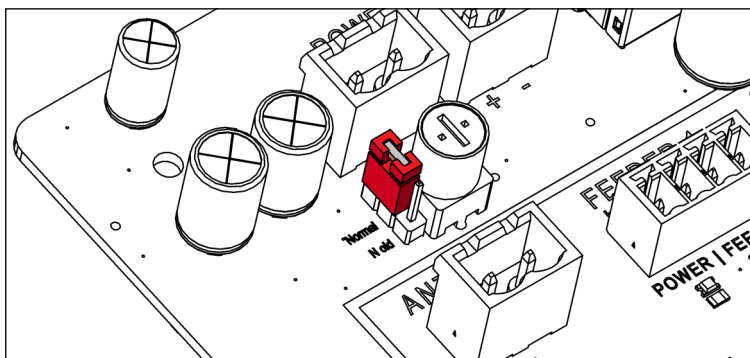

Attention! Do not use RFID interfering materials to realize the distance between the tag and the Antenna.

Tag Detection
✕

Place a tag at least 7 cm from Antenna 1 in feeding station A1 and press 'Start'.

Start
Cancel

Result of the tag detection is shown below.

Tag Detection
✕

Tag Detection finished

Success: Yes

Apply detected settings to all (connected) PCBs?

Yes
No

If no tag is found, this will be reported and the old settings will be restored. You can then manually try to read the tag by changing the SpiderPCB parameters. See chapter 4.3.4 on how to change SpiderPCB parameters.

4.3.2 Set factory defaults

Reset all parameters to default.

01 - 1
✕

Tag Detection
Led test
Set factory settings

 Show advanced params

Id	Description	Value	
30011	Enable Tagtypes	<input style="width: 100%;" type="text" value="48"/> <div style="font-size: 0.8em; margin-top: 5px;"> Tagtypes: <ul style="list-style-type: none"> HDX=1 FDX_B(ISO)=2 </div>	Save

4.3.3 LED test

All external LEDs on the Spider unit will be activated.

01 - 1
✕

Tag Detection
Led test
Set factory settings

 Show advanced params

Id	Description	Value	
30011	Enable Tagtypes	<input style="width: 100%;" type="text" value="48"/> <div style="font-size: 0.8em; margin-top: 5px;"> Tagtypes: <ul style="list-style-type: none"> HDX=1 FDX_B(ISO)=2 </div>	Save

4.3.4 Setting/fine-tuning parameters manually

This menu contains a number of settings that are normally set correctly with tag tuning but may be changed manually here.

Id	Description	Value	
30011	Enable Tagtypes	2 Tagtypes: <ul style="list-style-type: none"> ● HDX=1 ● FDX_B=2 ● DELAVAL=4 ● EM410x=8 ● NEDAP 1st gen=16 ● NEDAP 2nd gen=32 ● VCODE=64 ● ID2000=128 ● FULLWOOD=256 ● ALL=4294967295 Combi: HDX(1)+DELAVAL(4)=5	Save
30001	RFID: Frequency	134200	Save
30002	RFID: Multiplexetime, the time an Antenna is active (not	300	Save
30003	RFID: Holdtime, the maximum time between 2 reads	3000	Save
30007	RFID: LEDS on when detect (0=off/1=on)	0	Save

- **30011 Enable Tagtypes:** Specify the tagtype used. By adding up the values, multiple types of transponders can be read. Contact Hanskamp for more information about the possibilities.
- **30001 RFID Frequency:** Enter the best frequency for this tag in combination with the Antenna. To fine-tune, increase and decrease this value in steps of 500 to find the best setting for your situation.
- **30002 RFID Multiplexetime:** This is the time frame within which the Antenna is active and ready to read the tag. Only one Antenna will be active at a time. The value can be increased for slower transponders with a longer loading time (e.g. for tagtype 16, the setting should be at 2000). This setting is not used for HDX or DeLaval. In that situation, the Burst and Listentime must be set correctly.
- **30003 RFID Holdtime:** This is the time frame within which the tag must be read again to confirm that the same cow is still present. If the cow is not recognised every **3000 msec**, this time can be increased to allow the feeding process to continue during Holdtime. If no cow is identified during Holdtime, the feeding process will stop.
- **30007 RFID LEDS:** Set to 1, to activate an extra 'service' function in the LED indicator. On the front of the Spider unit, the LED corresponding to the active Antenna turns red. When a transponder is detected, the LED will light up/flash green. This is handy for testing and fine-tuning the Antennas. This setting is set to 0 by default to keep the LED indicator clear.

Check 'Advanced settings' to view and change more settings.

5. Adjusting the FloorAntenna



Caution! Ensure that the RFID settings are properly configured before setting up the FloorAntenna (frequency, transponder type, etc.).



Caution! Ensure that all FloorAntennas are connected and fixed in position. The mounting hardware must not be in contact with surrounding steel (e.g. concrete reinforcement).

Position the Spider unit in such a way that the LED lighting on the unit is visible from the point of adjustment.

1. Start de RFID LED's.
'Settings' -> 'Maintenance' -> log in as admin.

30003	Holdtime, the maximum time between 2 reads	<input type="text" value="4000"/>	<input type="button" value="Save"/>
20201	LEDS on when detect (0=off/1=on)	<input type="text" value="0"/>	<input type="button" value="Save"/>

2. 'Settings' -> 'Configuration SpiderPCB' -> choose the applicable SpiderPCB -> 'Parameters' -> 'RFID: LEDS on when detect (0=off/1=on)'. Set to '1'. This causes the LED associated with the connected Antenna(s) to light up red and flash green when transponder is recognized.
3. Loosen the adjusting screw in the EWA until the green LED switches off.
4. Hold the transponder facing outwards approx. 20 cm above the ground, just to the right of the centre within the boundaries of the Antenna (see below image). Use for example a piece of PVC tube to hold it in place.
5. Tighten the adjusting screw in the EWA until the LED for the relevant Antenna flashes green. If the adjusting screw is fully tightened but the transponder is still not being identified, move the transponder further in. If it is recognised, the EWA is correctly adjusted.
6. Test whether the transponder works everywhere within the Antenna and that there is no crosstalk with other Antennas. If there is crosstalk between Antennas, loosen the adjusting screw until the desired range is achieved.
7. Close the DEBUG mode. See step 1 and change 'RFID: LEDS on when detect (0=off/1=on)' back to '0' and click 'Save'.

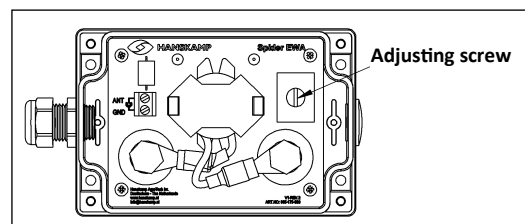

TIP: Use our FieldTester (art. no. 005-130-000) to adjust and check the field.

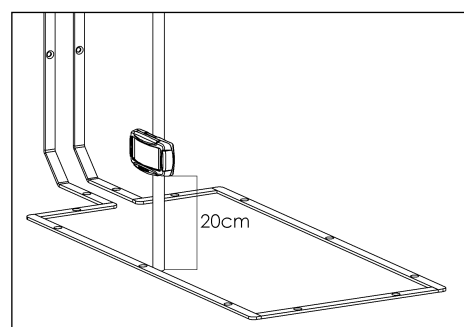

6. Using the LED indicators

The unit uses 16 RGB LEDs to indicate the Spider's current process.

The following is an overview of the various colours and their meanings.

Orange:	No communication with processor. This happens on the first start up. The Spider will establish its own network.
Light blue, crossfaded:	Stand by (waiting for next animal).
Blue:	Animal is feeding + indication of number of feed types. Example: 4 feeding stations with 4 feed types, if feeding station 1 is feeding and this animal is receiving 3 feed types, the first 3 LEDs will flash blue.
Green, flashing:	Feed motor is in operation; the LED matching the dispenser in operation will light up.
Yellow, crossfaded:	Waiting for animal to exit feeding station: the animal has no more feed credit or has not been recognised for a while.
Yellow, continuous:	(Only applicable in milking parlour.) If the limit switch is activated continuously, the yellow LED will remain lit up. Antenna recognition will remain inactive until the limit switch returns to the normal position.
Red, continuous:	Motor error: motor current is too high ($\pm 3A$) or is not giving feedback. If the motor responds normal the next time it is actuated, the error will disappear and this LED will no longer light up red. If a motor error occurs 3 times in a row (no feedback/overcurrent), the motor will be disabled for 10 minutes. After 10 minutes, the motor can be actuated again; if the error has disappeared, the LED will light up green again. For exact error reporting, see ' Feed overview ' in the user interface.
Red, flashing:	If all lights are flashing red, a motor is running continuously.
RFID LEDs	
Red:	Multiplexing (on = Antenna active).
Green:	Tag detected.

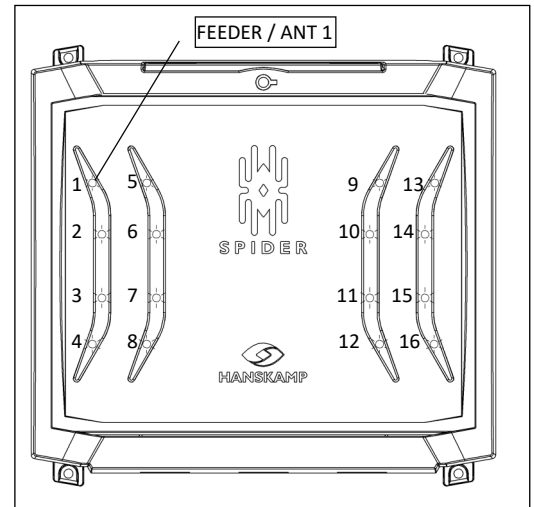

7. User interface



Daily attentions, notifications and overviews can be found on the dashboard. You can set the program to your liking in the various menus. There are total feed overviews, but also individual overviews that show performance. With a number of settings, you will find an 'i' for more information.

Log in as administrator via the menu '**System**' -> '**Maintenance**' -> '**General**' to access more permissions in the program.

7.1 Updates

7.1.1 Internet update

In the updates screen, the latest available version is shown under '**Web updates**' and '**Update version**'. '**Current version**' shows the version the system is currently running on. The update version is only shown if an internet connection is established. If the update version matches the current version, then the latest available version has been installed already. Click on '**Install**' to perform the update.

When asked "Are you sure you want to install this update?", click '**Yes**'. The installation of the update will take some time. The update process is finished once the SpiderLEDs are crossfading again in light blue. If you are logged in to Spider from a mobile device, you may need to re-establish your wi-fi connection. See chapter 4 '**Signing in / starting up**'.

7.1.2 USB update

If the Spider is not connected to the internet, the update can be performed by means of a USB stick. This USB stick is placed in the Spider on the CarrierBoard. Download the software via hanskamp.com/brochures-downloads -> search for '**Spider**', then choose -> '**Spider update**'. Copy the software onto the USB stick and place it back on the CarrierBoard. After some time, the update version will be displayed under '**Update**' from the USB stick. Click on '**Install**' to perform the update.

When asked "Are you sure you want to install this update?", click '**Yes**'. The installation of the update will take some time. The update process is finished once the SpiderLEDs are crossfading again in light blue. If you are logged in to Spider from a mobile device, you may need to re-establish your wi-fi connection. See chapter 4 '**Signing in / starting up**'.

7.1.3 Firmware update

Once the Spider software has been updated, the firmware of the SpiderPCB will be checked automatically and updated if necessary. The firmware can also be updated manually via '**Maintenance**' -> '**PCB Detection**'.

The version of the current bootloader and application is also displayed here.

The screenshot shows the 'Maintenance' screen with a navigation bar containing: General, SpiderConnect, Updates, System, Backup, TAURUS, Export data, Download Logs, and PCB Detection (highlighted). Below the navigation bar, there is a checkbox for 'Auto update PCBs on connect' which is checked. A table displays the following data:

	Address	IPv6	IPv4	MC	SN	BL Version	APP Version	
1		fe80::250:c2ff:fe92:1260	172.16.16.161	10001	1906184	V0.5-b040	V0.6-b085	Reboot PCB Update Firmware

7.2 Backup

A backup is made daily and a backup copy will be stored on the server as well as on the USB stick, if present in Spider. A copy of the backup can also be saved to the USB stick later on by clicking '**Download backup copy**'. By clicking '**Restore backup**', the current database will be overwritten with the backup.

If the backup is made manually via the '**Create backup**' button, a copy will be stored on the server, on the USB in Spider as well as on the device connected to Spider (PC, Tablet, iPad or mobile phone).

7.3 TAURUS-link with management system

TAURUS is the link between the Spider and the management system. The Spider uses the TAURUS-link to send and receive all feeding data to and from the management system. It is recommended to execute the data transmission at the end of every cycle.



Caution! Modifying feeding data or adding new animals must be done in the management system. Animals added or modified in the Spider will be overwritten after linking with TAURUS.

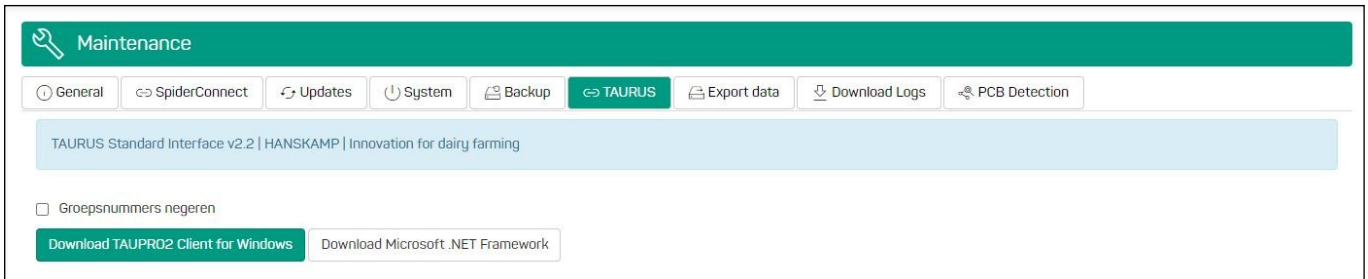

The TAURUS client must be downloaded before the link can be used. Click '**Download TAUPRO2 Client for Windows**'. This is a setup file which must be run to allow the program to work (this file can be found in your computer's default download folder: '**User/Downloads**'). A new screen will be displayed when running the setup. Choose the users who will be authorised to use the program and click '**Next**'. After installation, the screen can be closed with '**Close**'.

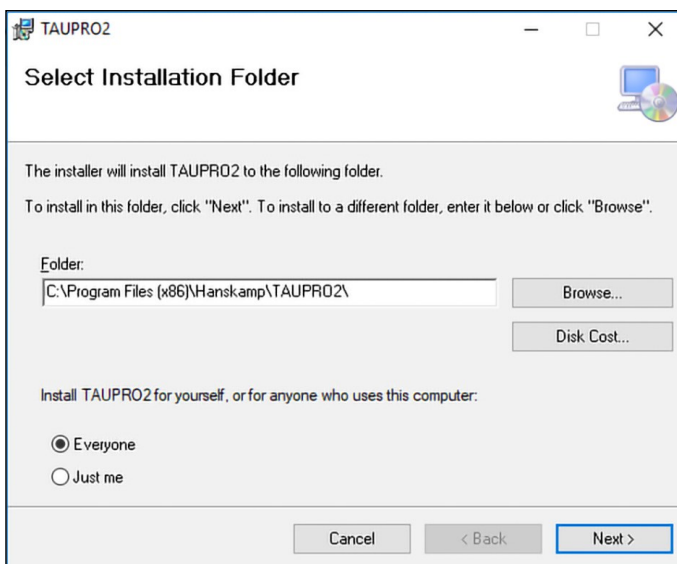

TAURUS link in combination with in-parlour feeding

If a TAURUS link is used in combination with a milking parlour, the quantity entered in the milking parlour takes precedence over the entered percentage. If both values have been entered, the absolute quantity fed in the milking parlour is used.

Which management programmes can be connected to the Spider?

Please contact Hanskamp for an overview. The Spider can currently only be connected with a management system using TAURUS.

If the setup was launched on a computer where an installation of the client is already present, the installer will ask if you want to:

- Update the current version -> '**Repair**'.
- Uninstall the current version. If you choose to uninstall the current version, your system may ask you to allow changes. The client is now uninstalled and the screen can be closed with '**Close**' -> '**Remove**'.



Other settings to establish the link must be configured by the helpdesk from your management program.

7.4 Manual motor settings

If another type of motor is used, the actuation time and interval time can be specified here.

🔧
Custom motor settings

Select 'Custom motor settings' type when configuring dosers in order to use these settings.

Feedback

SoftStart

Cycle time *1 ms

Active time *2 ms

Cancel Save

Feedback

After a motor has been actuated, feedback is expected within the cycle. After actuation, feedback is ignored for a set time (SpiderPCB parameter 50002 - Default = 500msec) to prevent the motor from stopping just before or when feedback is given. If the feedback option is selected, the feedback must be seen before the end of the cycle and the motor will stop.

Cycle

This is the time allowed for the motor to dispense one portion. A second actuation is only possible after the cycle has been completed. This means that the cycle must always (!) be greater than or equal to the actuation time.

Actuation time

This is the time that the exit of the motor is actuated (raised).

Soft Start

This setting is not used.

7.5 Calibration

Calibration is important to ensure correct feed dispensing. Perform a calibration with each new feed delivery or if the type of feed has been changed. Calibrate at least 2 times a year, to continuously ensure correct feed dispensing.

To calibrate, go to '**System**' -> '**Calibration**'.

🏠
Calibration

🏠 Dosers
🏷️ Calibration tags

SpiderPCB 01 Feeding station

SpiderPCB Connected	Feeding station	Feed type Doser no.	Portion size	Calibration date	
<input checked="" type="checkbox"/> 01 Feeding station	Feeding station 1	1 - Voersoort 1 FEEDER 1	60		Calibration...
<input checked="" type="checkbox"/> 01 Feeding station	Feeding station 1	2 - Voersoort 2 FEEDER 2	60		Calibration...
<input checked="" type="checkbox"/> 01 Feeding station	Feeding station 2	1 - Voersoort 1 FEEDER 5	60		Calibration...
<input checked="" type="checkbox"/> 01 Feeding station	Feeding station 2	2 - Voersoort 2 FEEDER 6	60		Calibration...

Then click on '**Calibration**' and follow the instructions on the screen. Use a (kitchen) scale to weigh the feed. Do this for each feeder.

7.6 User tips

Individually or on a group curve

You can opt for individual feeding or feeding per group curve. These options can be found on the animal card. The group curve is adjustable via groups. The curve of the selected group is always used. Individual set-up and breakdown can also be used for individual feeding. Furthermore, the feed dose per animal can easily be changed via **'Animals'** -> **'Feed doses'**.

Group entry

If you want to change the same things for several animals, you can do so via **'Group entry'**. Multiple animals can be selected simultaneously, making it easy to carry out changes for entire groups.

Shift = Selecting (without clicking)

Ctrl = Deselecting/removing from selection (without clicking)

Select a number of animals, then click on **'Group input'** to perform the desired action.

Parlour monitor - Live monitor

The animals that have been recognized can be seen via **'Overviews'** -> **'Live monitor'** or **'Parlour monitor'**.

E-mails

System notifications can also be sent by e-mail if the Spider is connected to the internet. This can be set via **'System'** -> **'E-mails'**.

Control gates and motors

Motors can be tested, and the gates of the feed box can be opened and closed via **'System'** -> **'Control gates and motors'**. The possibility to set a closing time is a handy feature. That way, e.g. a closing gate can be closed for 60 minutes during milking and will then open again automatically after the set time.

Silo management

An additional option is to apply silo management. This can be set via **'System'** -> **'Silo and feed types'**. The dashboard shows the filling level of the silo. A message will appear on the dashboard once the set minimum level has been reached.

Animals (94)			
<input type="checkbox"/>	#	Tag	
<input checked="" type="checkbox"/>	6553		740065530
<input checked="" type="checkbox"/>	6625		734066255
<input checked="" type="checkbox"/>	6713		767067135
<input checked="" type="checkbox"/>	6749		767067490
<input type="checkbox"/>	6754		767067546
<input type="checkbox"/>	6758		767067584
<input type="checkbox"/>	6818		925268181
<input type="checkbox"/>	6830		925268307
<input type="checkbox"/>	6846		925268460
<input type="checkbox"/>	6860		925268600
<input type="checkbox"/>	6861		925268617
<input type="checkbox"/>	6925		868169253
<input type="checkbox"/>	6938		868169385
<input type="checkbox"/>	6946		868169462
<input checked="" type="checkbox"/>	4	Zoeken	Zoeken
<input checked="" type="checkbox"/> Quick change (4 animals)		Add animal	

7.7 Reading animal data

An existing animal list can be imported using an .xlsx file (Excel). When loading the Excel file, the first line will appear behind the headers A-, B-, C-, etc.

Import animaldata

Make sure that the first row of the table is a header.

The animal number or animal tag (transponder) must be filled in. This tool will update existing animals. If an animal was matched by number, the tag can be updated and vice versa. Please note that the system does not accept duplicate animal numbers or tags.

Download Sample Excel
OpenOffice Calc
Refresh

Open a file (.xlsx - Microsoft Excel Workbook)



Note! Any animal data on the first line will not be imported.

The order of notation is not important, the fields can be allocated later. See the image below for an example of the Excel list, with the headers on line 1 and the data below. This example uses Feed1 and Feed2 for Feed Type 1 and Feed Type 2 in kg.

	A	B	C	D	E	F
1	No.	Tagno.	Ref-date	Feed1	Feed2	Group
2	5407	984000002284330	17-4-2018	1	0,7	1
3	5463	984000002284350	17-4-2018	0,5	0,8	1
4	5471	984000002284370	17-4-2018	0,3	0,9	1
5	5495	984000002284380	17-4-2018	0,3	1	1

Click on 'Select file' and select the file to be loaded.

The next screen will open.

Import animaldata

Download Sample Excel
OpenOffice Calc
Refresh

A - Name	B - Cow Number	C - Tag	D - Feed 1	E - Feed 2	F - Feed 3	G - Reference date
Name	Number	Tag	Feed type 1	Feed type 2	Feed type 3	Reference date
ELLINA	1312	2533661312		1.984	3.38	4/13/20
FARINE	1365	2533661365	3	2.4	3.5	11/6/20
IBIZA	1489	2533661489		1.736	3.224	2/16/20
INDOCHINE	1504	2533661504	2.36	2.4	3.5	4/10/20
JASMINE	1518	2533661518	1.28	2.256	3.5	9/13/20
JAZZY	1519	2533661519		0.732	1.356	2/7/20
JODELINE	1520	2533661520	3	2.4	3.5	11/25/20
JOLINESS	1528	2533661528	2.02	2.4	3.5	5/24/20
LINA	1550	2533661550				1/8/20
LADY	1551	2533661551	3	2.4	3.5	11/17/20

Start import

A - Name

Name

Number

Name

Tag

Group

Lactation number

Reference date

Feed type 1

Feed type 2

Feed type 3

Feed type 4

The data must now be allocated; this can be done by making a selection in the pull-down menu.

8. Explanation of the feeding principle

Spider ensures a proper distribution of feed throughout the day and monitors the amounts of feed supplied per visit. The amount the cow saves up is available to her throughout the day. The minimum saving amount is adjustable to prevent an animal from getting an infinite chunk.

The animal continues to save from the last visit to the feed station instead of from the start of the day. This prevents extra crowds around the feeding station.

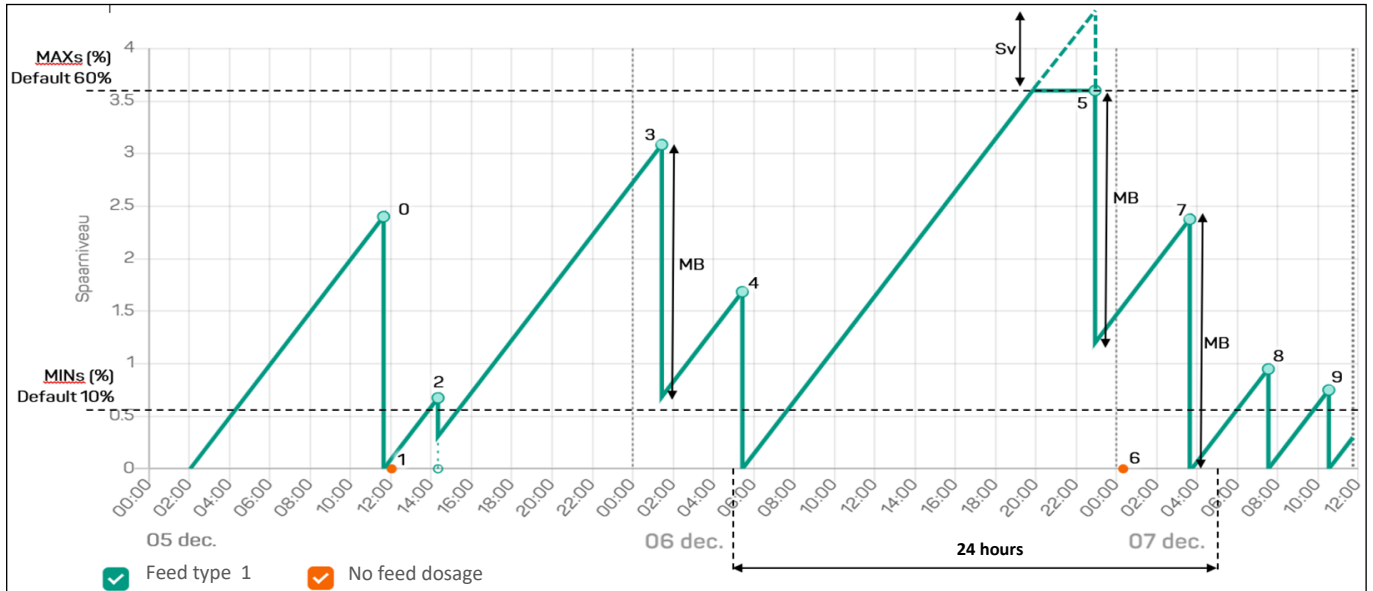

0. Normal visit - animal is eating saved feed amount
1. Not enough saved - animal will not be fed
2. Animal is eating part of the saved feed amount
3. More has been saved than may be eaten per visit. Animal is eating maximum feed amount
4. Normal visit - animal is eating saved feed amount
5. Animal has not visited the feeding station for a long time and has reached the maximum savings amount - she is eating the maximum feed amount per visit
6. No permission to feed - as she has eaten the maximum feed amount during the previous visit there must be a two hour time difference in between visits
7. Normal visit - animal is eating maximum feed amount per visit
8. Normal visit - animal is eating saved feed amount
9. Normal visit - animal is eating saved feed amount

MaxB = max amount per visit (60% of 3 kg = adjustable)

MaxS = max savings amount (60% = adjustable)

MinS = min savings amount (10% = adjustable)

Sv = savings loss *1

*1 this amount will be deducted from the daily dose because the animal has not visited

Prevention of overfeeding:

A cow may only eat the saved amount of concentrate. If this saved amount of concentrate is higher than the limit per visit, it will be adjusted to this limit. When an animal re-registers, it will not be fed if it has already received more than 90% of the total visit amount in the previous 2 hours.

Milking parlour: No higher amount than the visiting amount can be fed within a time frame of 4 hours. The visiting amount in a parlour is the total amount for the parlour/number of milkings. If the parlour is combined with feeding stations, the cows will not receive feed in the feeding station for an adjustable time after milking.

9. Replacing components

9.1 Replacing PCB

1. Go to '**System**', select the SpiderPCB to be updated, open the tab '**Parameters**' and make a note of the configurable values (e.g. in the empty fields behind the default values, see chapter 4.3).
2. De-energise the SpiderPCB.
3. Disconnect all of the cables. Make sure that the cables are numbered so that they are put back in the correct place later (tip: use the order in the cable entry plate).
4. Unscrew the SpiderPCB and replace it with the new one.
5. Reconnect all cables as they were connected on the old board.
6. Configure the address with the dip switches.
7. Connect the power supply (24VDC).
8. Set the jumper to the correct position (see old board for correct position).
9. Make sure that the right firmware is installed on the PCB. See chapter 7.3.1.
10. Set the SpiderPCB parameters using the values noted in step 1. If the values are unknown, configure them now: '**Parameters**' -> '**Set default values**' -> '**Tag Detection**' (see chapter 4.3).
11. Test all inputs and outputs.

9.2 Replacing Antenna

1. Disconnect the Antenna cable from the SpiderPCB (connector).
2. Remove the Antenna and cable.
3. Install the new Antenna; make sure it is the same type: 134.2 kHz or 120 kHz (black). Run the cable into the Spider unit. Ensure that it is out of reach of the animals.
4. Connect the cable to the position the old cable was removed from.
5. Test the Antenna with a transponder.

9.3 Replacing CarrierBoard

1. Create a backup before replacing the CarrierBoard, if possible.
2. De-energise the CarrierBoard.
3. Disconnect the ethernet cables (WAN and LAN).
4. Replace the old CarrierBoard with the new one.
5. Connect the power cable and the ethernet cables.
6. Remove the paper between the battery and the tab of the battery compartment to allow contact.
7. Update the CarrierBoard to the latest version. See chapter 7.1.
8. Upload the backup from the old CarrierBoard (if no backup is available, configure the system). See chapter 7.2.
9. Restart the system: '**Maintenance**' -> '**System**' -> '**Restart system**'.
10. Test the system with a transponder.

10. Extra information

Maintenance

Calibrate the system regularly to avoid irregularities. The system must always be recalibrated when switching feed types.



Caution! To prevent accidents, disconnect the system from the power supply before making modifications to the Spider.

Disassembly

When dismantling the Spider, all components must be separated according to material type and added to the appropriate waste processing cycle.



Caution! When dismantling the Spider, always de-energise it first by removing the plug from the electrical outlet.

Overview of changes made in these installation and operating instructions

No.	Release date	Chapter(s)	Comments
1.0	12/2018		First edition
1.1	06/2019	All	Update to UI v2.0
2.0	08/2019	All	Update to newest version
2.1	11/2019	7	Update 7.5.1.2
2.2	12/2019	Multiple	Update to Spider App (IOS, Android)
3.0	10/2021	All	Update to UI 3.0
3.1	01/2023	Pages 10 + 37	UKCA logo added
3.2	04/2025	Pages 12, 15, 17, 20, 21, 42, 43, 44, 45	Pg. 12 replaced image, pg. 15 image 11, 10 cm distance line inserted, pg. 17, brown and green wire swapped, was wrong, pg. 20 text cluster antenna and images added, pg. 21 Spider write all in capital letters when logging in, pg. 42 and 43 different layout, pg. 44 connection diagram inserted in the table, RIM Time feedback was no, is now yes, text more expensive motor removed from IM, RIM pulse and time, pg. 45 extra wi-fi dongle inserted, Spider back up from 16 to 32 GB.
3.2.1	06/2025	Pages 34 and 44	Page 34 MaxB has changed from 40% to 60%. Page 44 RIM pulse becomes IM pulse. At Nedap motor the text of wire red on green has been changed to wire red on grey.
3.2.2	12/2025	Pages 1 + 46	Page 1 Change of place name. Page 46 Change of address Hanskamp.

Version management software

Version	Date	Modified	Comments
2.0	06/2019	Start	First worldwide available version
3.0	10/2021	All	Changes in layout and feeding principles

Warranty limitations

Costs and expenses resulting from the following are excluded from the warranty:

- Using the equipment improperly, in violation of the specifications in the installation and operating instructions;
- The consequences of any intervention by mechanics other than mechanics approved by Hanskamp for carrying out certain work;
- Incidents such as freezing, ice, fire, flood, flooding or any other problems caused by excessive water, and lightning;
- Defective electrical system or earthing;
- Using compressed air that does not meet Hanskamp's quality standards;
- Damage to the electrical system caused by pests and the like.

The warranty does not apply to consequential damages unrelated to the machine itself. All systems have been tested, However, in the event of defects, Hanskamp AgroTech BV cannot be held responsible for consequential damage.

11. Declaration of incorporation of complete machines IIA**According to Annex IIA of the Machinery Directive 2006/42/EC, for completed machines**

We,
Hanskamp AgroTech BV
Broekstraat 17
7009 ZB Doetinchem
The Netherlands,

Authorised compiler(s) of the technical file:

H.J. Hanskamp,

declare under our sole responsibility that the following product:

5000 Spider
Control unit for various milking parlour feeding systems from Hanskamp AgroTech BV,

to which this declaration relates, complies with the provisions of the following directive(s):

- Machinery Directive 2006/42/EC

The product also complies with the provisions of the following standards:

- NEN-EN-ISO 12100
- NEN-EN-ISO 4414
- NEN-EN-IEC 60204-1
- NEN-EN-IEC 13849-1

If the Spider is not connected and the prescribed safety instructions are not used, this Declaration of Conformity is not applicable and no rights can be derived from this declaration.

Doetinchem, the Netherlands, 01-08-2019

H.J. Hanskamp



12. Notifications & FAQ

12.1 Notifications

Program notifications	Possible cause	Solution
x hour not fed	<ul style="list-style-type: none"> Entrance to the feed station is blocked Cows have been outside in the field for a long time Antenna doesn't recognize transponders (test with a random transponder and check if transponder is shown on the live monitor) 	<ul style="list-style-type: none"> Remove blockage If there is no recognition, try another Antenna input, repair cable, or replace Antenna
Motor error (over current)	<ul style="list-style-type: none"> Doser runs heavy/ is clogged Motor runs heavy/ is broken Connection error 	<ul style="list-style-type: none"> Remove clogging Replace Motor Connect the Motor properly and/ or try another exit on the PCB (see chapter 4.2)
Motor error (no feedback)	<ul style="list-style-type: none"> Motor has no feedback Connection error Motor takes to much time for rotation 	<ul style="list-style-type: none"> Change Motor settings by 'Settings' -> 'Custom motor settings' Connect the Motor properly and/ or try another exit on the PCB
Motor fault (short circuit)	<ul style="list-style-type: none"> Water damage or cable break Motor defective 	<ul style="list-style-type: none"> Replace motor or cable
Motor error (motor runs continuously)	<ul style="list-style-type: none"> Electronics part in PCB defective Continuous power on motor input 	<ul style="list-style-type: none"> Switch motor to another output and configure
Backup failed	<ul style="list-style-type: none"> USB not placed correctly Can not save backup 	<ul style="list-style-type: none"> Remove USB and reinstall it Restart Spider
PCB x not connected	<ul style="list-style-type: none"> This PCB is configured, but has no connection 	<ul style="list-style-type: none"> Delete configuration Fix PCB connection
Server reboots often	<ul style="list-style-type: none"> The SpiderServer has been restarted more than 3 times 	<ul style="list-style-type: none"> Problem with power supply Restarted several times due to e.g. an update

Copyright and disclaimer

The information in this publication is for informational purposes only, and is not intended as a sales quote. The products offered may differ from the images. Any brand or product references in this manual are for identification purposes only. The company and product names mentioned in this manual are trademarks. No part of this publication may be reproduced or made public without the prior written consent of Hanskamp AgroTech BV. Although this publication has been compiled with the greatest care, Hanskamp AgroTech BV is not liable for any damage that may arise due to any errors or omissions it might contain. The Dutch installation and operating instructions are the original installation and operating instructions. Translations into other languages are based on the Dutch installation and operating instructions as a source document. Hanskamp AgroTech BV accepts no liability for differences between the translations. If there are any doubts about the content and accuracy of the translated installation and operating instructions, the Dutch installation and operating instructions shall prevail.

12.2 FAQ

Problem	Possible cause	Solution
Motor does not rotate 10 times during calibration	<ul style="list-style-type: none"> Feedback fault on motor 	<ul style="list-style-type: none"> Check feedback operation
Faltering or no recognition (with one Antenna)	<ul style="list-style-type: none"> Connection to the SpiderPCB Cable damage (e.g. because of damage caused by rodents) 	<ul style="list-style-type: none"> Check all Antennas with a test transponder and see if the problem occurs everywhere Check the connection to the SpiderPCB (cable in connector and connector on PCB) Replace Antenna
Faltering or no recognition (with all Antennas)	<ul style="list-style-type: none"> Adjustment on SpiderPCB expired or adjusted External interference (caused by interfering transmitters such as a frequency converter or solar inverter) 	<ul style="list-style-type: none"> Reset PCB Remove the source of interference Have the grounding of the faults checked externally
Feed data not forwarded from management program	<ul style="list-style-type: none"> New PC Time setting 	<ul style="list-style-type: none"> Install or check the Taurus program on your PC, see chapter 7 Check if the time of Spider is correct. If not, adjust it Check if the link with your management program has started/ is running Check if you can approach the Spider via your PC (on which the management program is installed). If not, restore network connection. Otherwise contact the helpdesk of your management program
Spider wi-fi no longer visible or not connectable on mobile device	<ul style="list-style-type: none"> Wi-fi service no longer active There is no contact with wi-fi dongle Problem with user device (laptop, phone or tablet) 	<ul style="list-style-type: none"> Turn wi-fi on device off and on again When wi-fi is not connectable forget wi-fi and search again Restart Spider (10 sec. powerless) Try another device Plug wi-fi dongle into other USB output
Spider can be reached via Spider network (172.16.16.1) but not via home network	<ul style="list-style-type: none"> Spider gets an IP address from the router. Spider may receive a new IP address after e.g. a power failure No connection between Spider (barn) and home router 	<ul style="list-style-type: none"> Connect within the Spider network (see chapter 4) Check if the router is sending an IP address (menu 'Maintenance' -> 'SpiderConnect')
Router's IP address contains question marks	<ul style="list-style-type: none"> Poor connection 	<ul style="list-style-type: none"> Restart Spider Check plugs and cable for damage and replace if necessary
Not all admin settings are visible.	<ul style="list-style-type: none"> Not signed in as admin; the system signs out automatically after 5 minutes of inactivity 	<ul style="list-style-type: none"> Sign in as admin again -> 'Maintenance' -> 'Enable administrator features'
The SpiderPCB cannot connect (orange LED)	<ul style="list-style-type: none"> Error during update or startup No connection between CarrierBoard and SpiderPCB 	<ul style="list-style-type: none"> 'Maintenance' -> PCB detection shows an overview of all linked SpiderPCBs at UDP level. Update the firmware here Remove the network connection between both circuit boards and reboot the system. Then reinsert the network cable
No longer feeds or displays data at all	<ul style="list-style-type: none"> Database problem 	<ul style="list-style-type: none"> Try to restore a backup (chapter 7)
Can't log in via the app	<ul style="list-style-type: none"> Phone no connection 	<ul style="list-style-type: none"> Go to wi-fi settings and select 'Spider', enter password 'hkfsspider'. The user environment can now be accessed via the web browser. Enter the IP address 172.16.16.1 (not in the search engine)

13. Appendices

13.1 Appendix SpiderServer

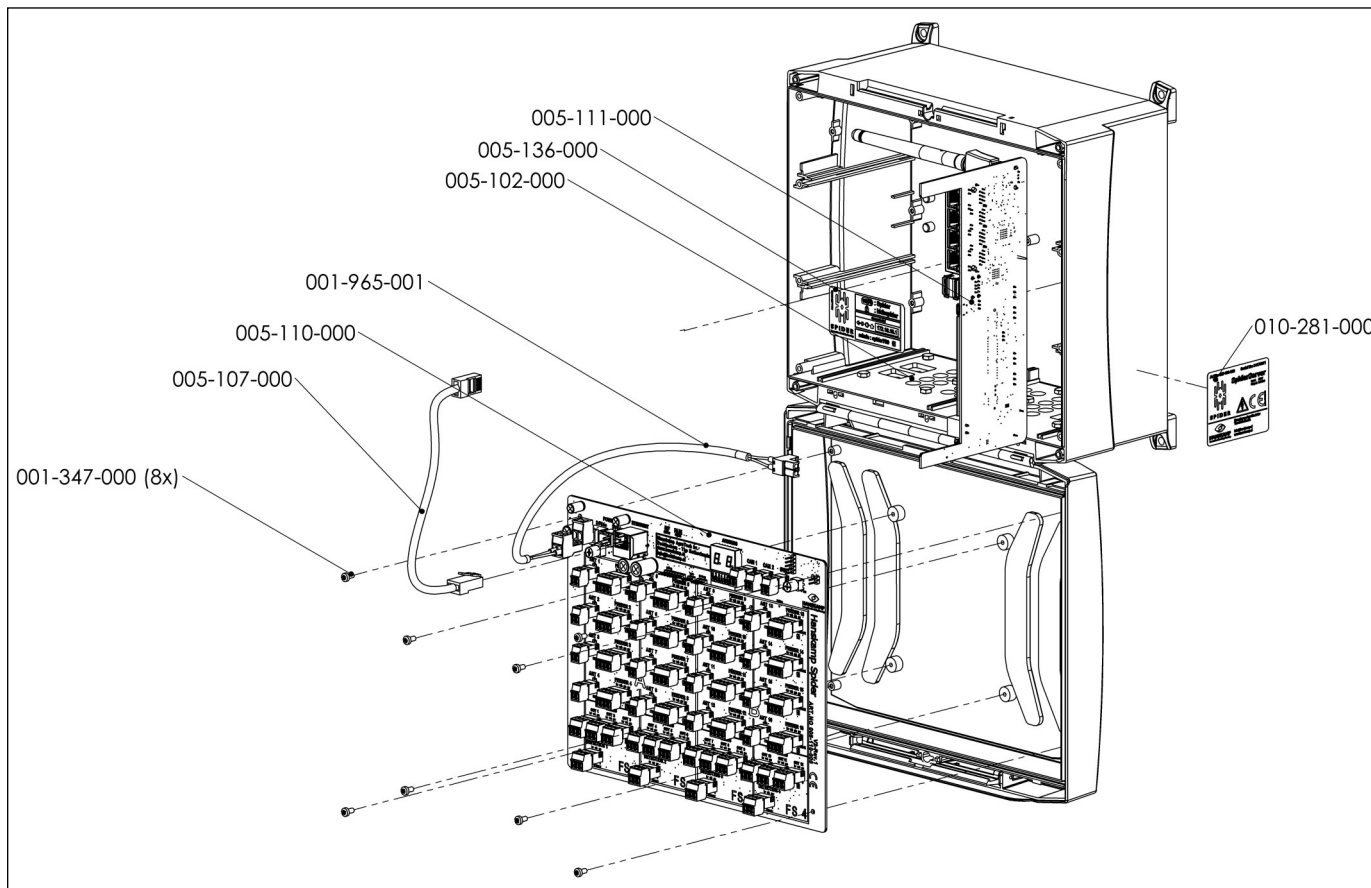

Description of parts SpiderServer art. no. 005-100-000

Art. no.	Description	Quantity
001-347-000	Tap bolt M3x6 a2 cross recessed DIN 7958	8
001-965-001	Power cable 2x1.5mm LiYY /0.25m	1
005-102-000	Spider enclosure with cutout	1
005-103-000	Set with fastening material for Spider enclosure	1
005-107-000	Communication cable between CarrierBoard and SpiderPCB in SpiderServer	1
005-110-000	SpiderPCB FSCU Control board 16 feeders - 16 readers	1
005-111-000	Spider CarrierBoard with switch, wi-fi and backup USB	1
005-112-000	Battery 3v 68mAh	1
005-113-000	Wi-fi USB dongle 300Mbps	1
005-117-000	Spider backup USB	1
005-136-000	Sticker for inside Spider enclosure with connection data	1
010-281-000	Serial number sticker with CE on housing SpiderServer	1
010-299-000	Service info LED use Spider (NL-EN-DE-FR)	1

13.2 Appendix SpiderClient

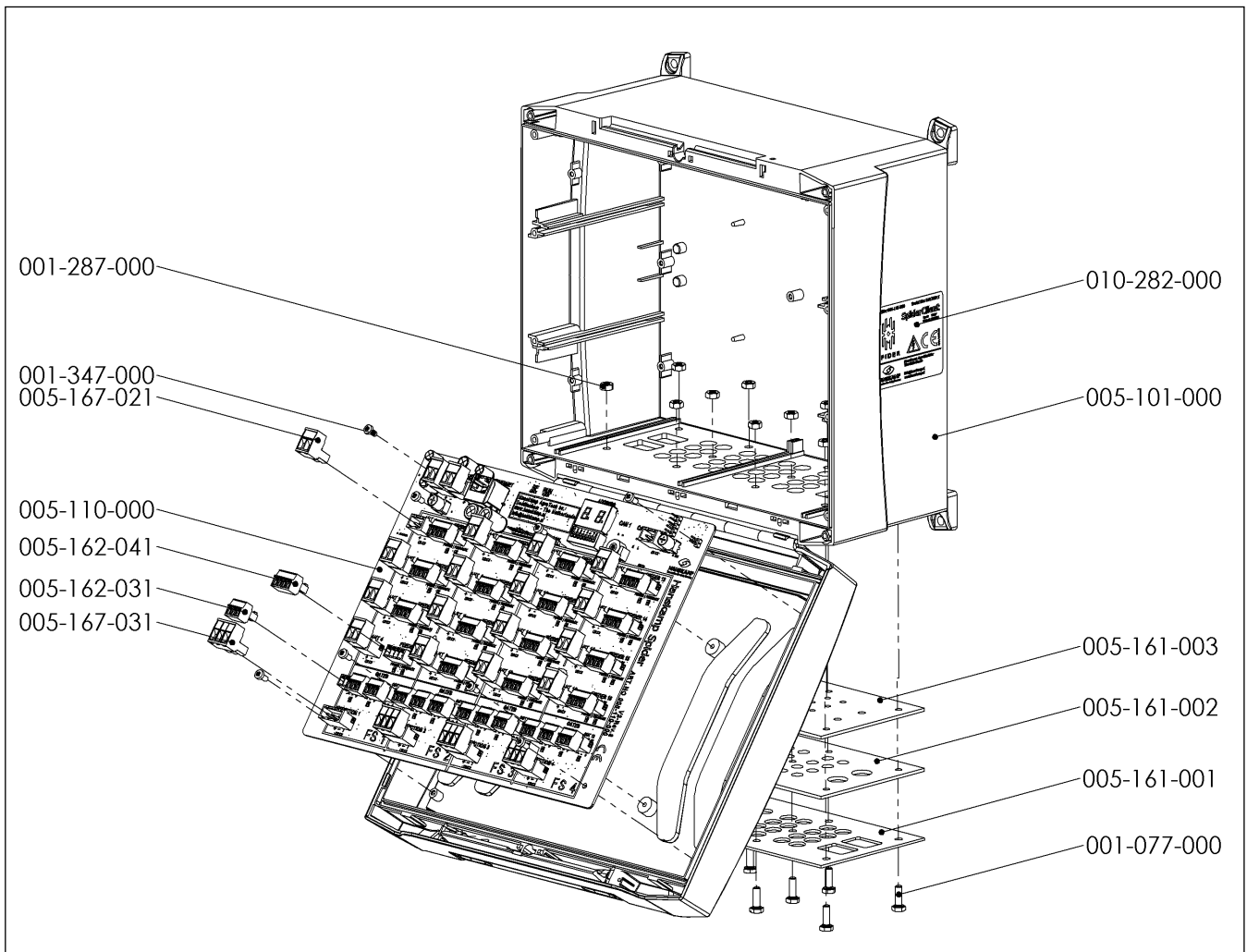

Description of parts SpiderClient art. no. 005-115-000

Article number	Description	Quantity
001-347-000	Tap bolt M3x6 A2 cross recessed DIN 7958	8
005-102-000	Spider enclosure with cutout	1
005-103-000	Set with fastening material for Spider enclosure	1
005-110-000	SpiderPCB FSCU Control board 16 feeders - 16 readers	1
010-282-000	Serial number sticker with CE on housing SpiderServer	1

Connectors SpiderPCB		
Article number	Description	Quantity
005-167-021	Connector SpiderPCB 5.08 mm plug 2-pole	18
005-162-031	Connector SpiderPCB 3.5 mm plug 3-pole	12
005-162-041	Connector SpiderPCB 3.5 mm plug 4-pole	16
005-167-031	Connector SpiderPCB 5.08 mm plug 3-pole	4

13.3 Appendix Description parts Hanskamp Antenna

Article number	Description	Quantity
005-145-100	SpiderAntenna 120 kHz black	*
005-150-200	SpiderAntenna 134.2 kHz green	*
005-150-300	SpiderAntenna 134.2 kHz blue	*
005-150-400	SpiderAntenna 134.2 kHz red	*
005-150-500	SpiderAntenna 134.2 kHz orange	*
Loose parts		
001-509-000	Mushroom head square neck bolt M8x60 DIN 603	4
001-769-000	Prevailing torque type hexagon nut M8 A2 DIN 985 coat	4
001-774-000	Washer M8 DIN 9021 A2	4
005-156-000	Backplate stainless steel 1.5 mm for SpiderAntenna	1

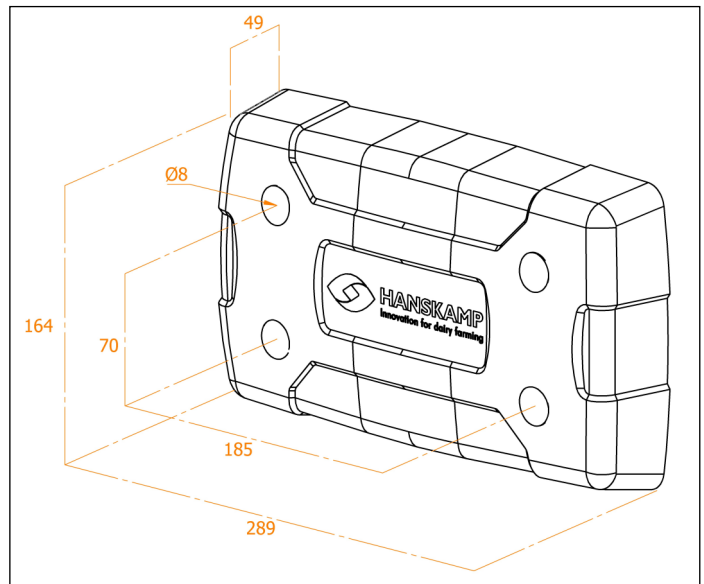
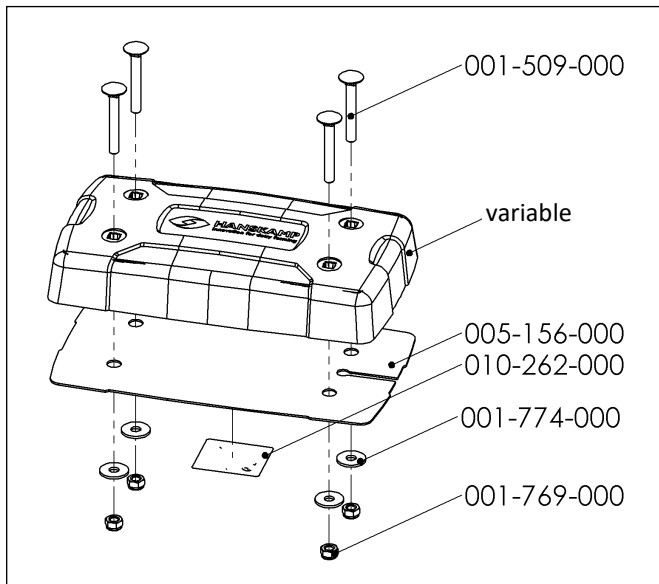

13.4 Appendix FloorAntenna

Art. no.	Description	Quantity
005-165-001	Hanskamp FloorAntenna	1
005-168-000	Set with fastening material for FloorAntenna	1
005-175-000	Spider EWA Transformer Antenna in enclosure	1

Art. no.	Description	Quantity
002-054-000	Screw torx 6x60 A2 T25 ve100	1
002-059-000	Nylon universal plug quattro SX 8mm ve100	1
011-090-000	Grip seal bag 80x120x0.05mm	1

Art. no.	Description	Quantity
001-043-100	Hexagon nut M8 A2 DIN 439	4
001-347-000	Tap bolt M3x6 A2 cross recessed DIN 7958	4
001-542-000	Bolt M8x30 A2 DIN 933	2
001-747-000	Motor control box	1
001-769-000	Prevailing torque type hexagon nut M8 A2 DIN 985 coat	2
001-774-000	Washer M8 DIN 9021 A2	4
001-829-000	Cable gland M16x1.5	1
001-832-000	Blind coupling M16x1.5	1
005-153-000	Coaxial cable RG58-U 15m	1
005-176-000	PCB EWA Antenna Trafo	1
010-280-000	Sticker on housing EWA Transformer Antenna	1

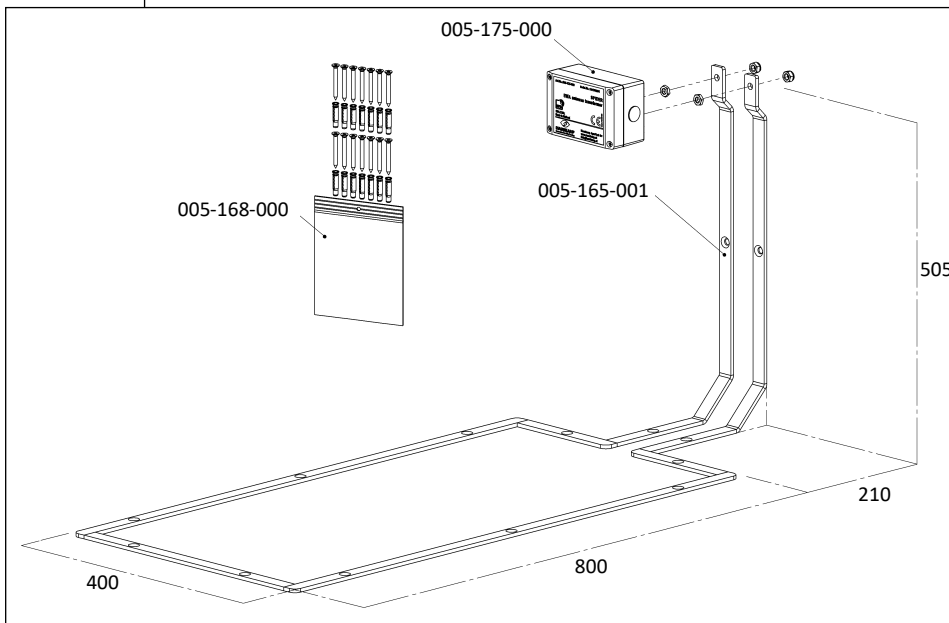
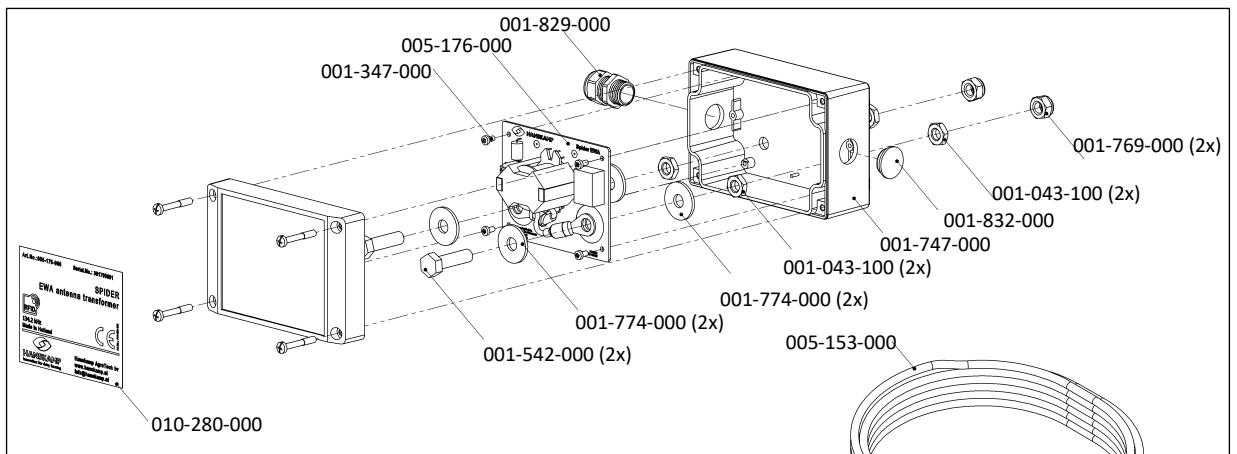
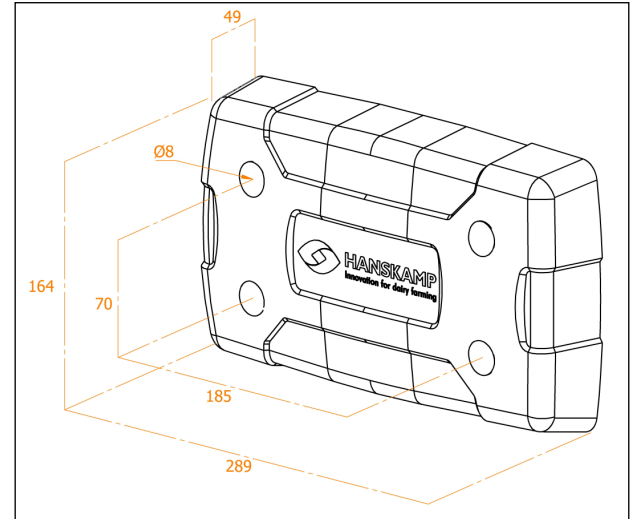

13.5 Appendix Control motors

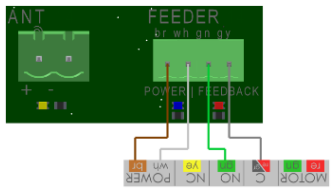
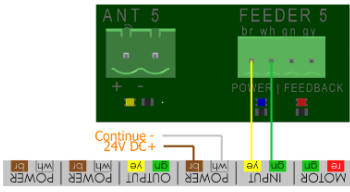
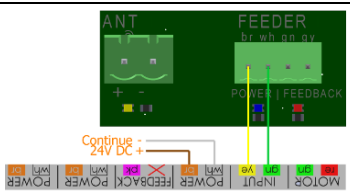
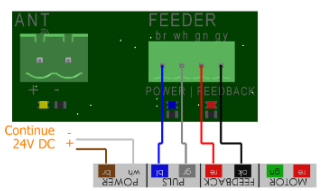
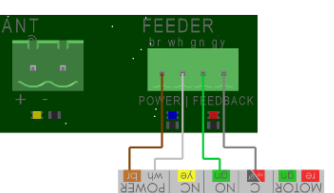
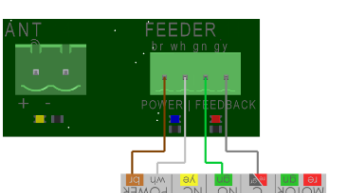
Motor	Possible	Feedback	Notes	Connection diagram
SolidState 5 (SS5) [now also 011-021-100 with 15 m cable]	Yes - Standard	Yes	Standard motor with which Spider was developed.	
SolidState+	Rather not	No	Old motor - Preferably replace with a SolidState 5. SolidState+ can be used. Connect brown, white and green, and add a 2k2 resistor to green and grey.	
Intelligent Motor	Yes	No	No feedback, not recommended.	
IM Pulse	Yes	No	Feedback, do not connect.	
RIM Time	Yes	Yes >V3.6	Feedback possible from V3.6.	
Grey motor	Yes	Yes	Downside to slide contacts and less power as it is 40 RPM. Preferably replace with a SolidState 5.	
Black Nedap motor	Yes	Yes	Huge disadvantages are the slide contacts and the fact that this motor draws much more current. Preferably replace it with a SolidState 5. When connecting a Nedap motor, connect red to the grey connection.	
AC motors	No	No	Possible if relay is used, but without feedback. Not recommended. Not anti-spill.	
DC time-controlled motors	Yes	No	Not advised by Hanskamp, but possible. Not anti-spill.	

14. Accessories

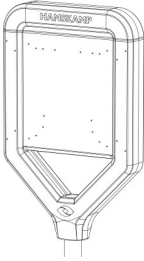
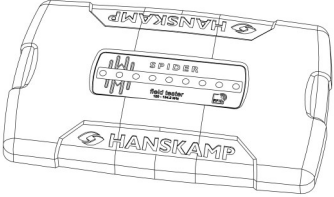
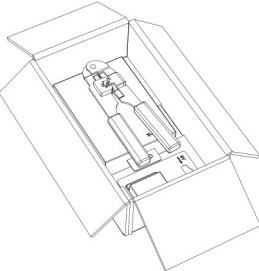
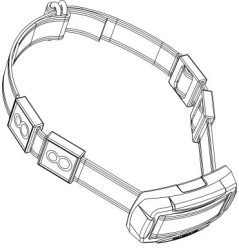
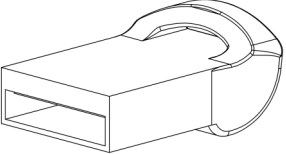
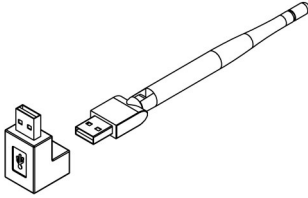
<p>Spider assembly unit Spider assembly unit can be used to install the Spider-Server or SpiderClient above the feeding station. As the assembly unit is hollow, remaining cables can be tied up inside it, preventing the animals from reaching them.</p>	<p>Art. no. 004-247-00*</p> 
<p>Spider FieldTester 134.2 kHz Spider FieldTester 134.2 kHz can be used to adjust the Antenna field for an EWA Antenna Transformer (FloorAntenna) or to check the signal strength of a normal Antenna.</p>	<p>Art. no. 005-130-000</p> 
<p>Crimping tool and tester Crimping tool and tester set to place the connector on an SF/UTP cable.</p>	<p>Art. no. 005-166-000</p> 
<p>SpiderTag / Collar / Numbers</p>	<p>Art. no. 005-061-000</p> 
<p>Spider Backup USB 32 GB</p>	<p>Art. no. 005-117-000</p> 
<p>Extra wi-fi dongle for hotspot functionality</p>	<p>Art. no. 005-125-000</p> 

Hanskamp AgroTech BV
Xenonstraat 6
7031 HX Wehl
The Netherlands
Tel: +31 (0)314 - 393 797
www.hanskamp.com

Download the Spider app:



Also take a look at:

